

PREPARED BY: DATE	SHARP	SPEC No. LD-K22109
APPROVED BY: DATE		FILE No.
		ISSUE: Jan,29, 2010
		PAGE : 24 pages
	AVC LIQUID CRYSTAL DISPLAY GROUP SHARP CORPORATION SPECIFICATION	APPLICABLE GROUP AVC LIQUID CRYSTAL DISPLAY GROUP

DEVICE SPECIFICATION FOR

TFT - LCD module

MODEL No. LK460D3LA63

CUSTOMER'S APPROVAL

DATE _____

BY _____

PRESENTED

BY _____

T.Suzuki
GENERAL MANAGER
MODULE DEVELOPMENT CENTER
AVC LIQUID CRYSTAL DISPLAY GROUP
SHARP CORPORATION

1. Application

This specification applies to the color 46.0" TFT-LCD module LK460D3LA63

- * These specification are proprietary products of SHARP CORPORATION (“SHARP”) and include materials protected under copyright of SHARP. Do not reproduce or cause any third party to reproduce them in any form or by any means, electronic or mechanical, for any purpose, in whole or in part, without the express written permission of SHARP.
- * In case of using the device for applications such as control and safety equipment for transportation (aircraft, trains, automobiles, etc.), rescue and security equipment and various safety related equipment which require higher reliability and safety, take into consideration that appropriate measures such as fail-safe functions and redundant system design should be taken.
- * Do not use the device for equipment that requires an extreme level of reliability, such as aerospace applications, telecommunication equipment (trunk lines), nuclear power control equipment and medical or other equipment for life support.
- * SHARP assumes no responsibility for any damage resulting from the use of the device that does not comply with the instructions and the precautions specified in these specification.
- * Contact and consult with a SHARP sales representative for any questions about this device.

2. Overview

This module is a color active matrix LCD module incorporating amorphous silicon TFT (Thin Film Transistor). It is composed of a color TFT-LCD panel, driver ICs, control circuit, and edge-lit LED backlight system etc. Graphics and texts can be displayed on a 1920 × RGB × 1080 dots panel with one billion colors (RGB 10bits) by using LVDS (Low Voltage Differential Signaling) to interface, +12V of DC supply voltages.

And in order to improve the response time of LCD, this module applies the Over Shoot driving (O/S driving) technology for the control circuit. In the O/S driving technology, signals are being applied to the Liquid Crystal according to a pre-fixed process as an image signal of the present frame when a difference is found between image signal of the previous frame and that of the current frame after comparing them.

With this technology, image signals can be set so that liquid crystal response completes within one frame. As a result, motion blur reduces and clearer display performance can be realized.

This LCD module also adopts Double Frame Rate driving method.

With combination of these technologies, motion blur can be reduced and clearer display performance can be realized.

3. Mechanical Specifications

Parameter	Specifications	Unit
Display size	116.8 (Diagonal)	cm
	46.0 (Diagonal)	inch
Active area	1018.08 (H) x 572.67 (V)	mm
Pixel Format	1920(H) x 1080(V) (1pixel = R + G + B dot)	pixel
Pixel pitch	0.53025 (H) x 0.53025 (V)	mm
Pixel configuration	R, G, B vertical stripe	
Display mode	Normally black	
Unit Outline Dimensions (*1)	1065.9 (W) x 617.4 (H) x 28.6 (D)(max)	mm
Mass	10.2 ± 1.0	kg
Surface treatment	Low-Haze Anti Glare Hard coating: 3H Haze value: 8%(typ)	

(*1) Outline is shown in Fig.1

4. Input Terminals

4.1. TFT panel driving

CN1 (Interface signals and +12V DC power supply)

Using connector : FI-RE51S-HF (Japan Aviation Electronics Ind., Ltd.)

Mating connector : FI-RE51HL, FI-RE51CL (Japan Aviation Electronics Ind., Ltd.)

Mating LVDS transmitter : THC63LVD1023 or equivalent device

Pin No.	Symbol	Function	Remark
1	GND		
2	Reserved	It is required to set non-connection(OPEN)	Pull up 3.3V
3	Reserved	It is required to set non-connection(OPEN)	Pull up 3.3V
4	Reserved	It is required to set non-connection(OPEN)	Pull up 3.3V
5	FRAME	Frame frequency setting 1:60Hz 0:50Hz [Note 1]	Pull down : (GND)
6	O/S set	O/S operation setting H:O/S_ON, L:O/S_OFF [Note 3]	Pull up 3.3V
7	SELLVDS	Select LVDS data order [Note 2]	Pull down : (GND)
8	Reserved	It is required to set non-connection(OPEN)	Pull down : (GND)
9	R/L	It is required to set H(3.3V) [Note 4]	Pull down : (GND)
10	U/D	It is required to set H(3.3V) [Note 4]	Pull down : (GND)
11	GND		
12	AIN0-	Aport (-)LVDS CH0 differential data input	
13	AIN0+	Aport (+)LVDS CH0 differential data input	
14	AIN1-	Aport (-)LVDS CH1 differential data input	
15	AIN1+	Aport (+)LVDS CH1 differential data input	
16	AIN2-	Aport (-)LVDS CH2 differential data input	
17	AIN2+	Aport (+)LVDS CH2 differential data input	
18	GND		
19	ACK-	Aport LVDS Clock signal(-)	
20	ACK+	Aport LVDS Clock signal(+)	
21	GND		
22	AIN3-	Aport (-)LVDS CH3 differential data input	
23	AIN3+	Aport (+)LVDS CH3 differential data input	
24	AIN4-	Aport (-)LVDS CH4 differential data input	
25	AIN4+	Aport (+)LVDS CH4 differential data input	
26	GND		
27	GND		
28	BIN0-	Bport (-)LVDS CH0 differential data input	
29	BIN0+	Bport (+)LVDS CH0 differential data input	
30	BIN1-	Bport (-)LVDS CH1 differential data input	
31	BIN1+	Bport (+)LVDS CH1 differential data input	
32	BIN2-	Bport (-)LVDS CH2 differential data input	
33	BIN2+	Bport (+)LVDS CH2 differential data input	
34	GND		
35	BCK-	Bport LVDS Clock signal(-)	
36	BCK+	Bport LVDS Clock signal(+)	
37	GND		
38	BIN3-	Bport (-)LVDS CH3 differential data input	
39	BIN3+	Bport (+)LVDS CH3 differential data input	
40	BIN4-	Bport (-)LVDS CH4 differential data input	
41	BIN4+	Bport (+)LVDS CH4 differential data input	
42	GND		
43	GND		
44	GND		
45	GND		
46	GND		
47	Reserved (VCC)	(+12V Power Supply)	

48	VCC	+12V Power Supply	
49	VCC	+12V Power Supply	
50	VCC	+12V Power Supply	
51	VCC	+12V Power Supply	

CN2 (Interface signals)

Using connector : FI-RE41S-HF (Japan Aviation Electronics Ind., Ltd.)

Mating connector : FI-RE41HL, FI-RE41CL (Japan Aviation Electronics Ind., Ltd.)

Pin No.	Symbol	Function	Remark
1	Reserved (VCC)	(+12V Power Supply)	
2	Reserved (VCC)	(+12V Power Supply)	
3	Reserved (VCC)	(+12V Power Supply)	
4	Reserved (VCC)	(+12V Power Supply)	
5	Reserved		
6	Reserved		
7	Reserved		
8	Reserved		
9	GND		
10	CIN0-	Cport (-)LVDS CH0 differential data input	
11	CIN0+	Cport (+)LVDS CH0 differential data input	
12	CIN1-	Cport (-)LVDS CH1 differential data input	
13	CIN1+	Cport (+)LVDS CH1 differential data input	
14	CIN2-	Cport (-)LVDS CH2 differential data input	
15	CIN2+	Cport (+)LVDS CH2 differential data input	
16	GND		
17	CCK-	Cport LVDS Clock signal(-)	
18	CCK+	Cport LVDS Clock signal(+)	
19	GND		
20	CIN3-	Cport (-)LVDS CH3 differential data input	
21	CIN3+	Cport (+)LVDS CH3 differential data input	
22	CIN4-	Cport (-)LVDS CH4 differential data input	
23	CIN4+	Cport (+)LVDS CH4 differential data input	
24	GND		
25	GND		
26	DIN0-	Dport (-)LVDS CH0 differential data input	
27	DIN0+	Dport (+)LVDS CH0 differential data input	
28	DIN1-	Dport (-)LVDS CH1 differential data input	
29	DIN1+	Dport (+)LVDS CH1 differential data input	
30	DIN2-	Dport (-)LVDS CH2 differential data input	
31	DIN2+	Dport (+)LVDS CH2 differential data input	
32	GND		
33	DCK-	Dport LVDS Clock signal(-)	
34	DCK+	Dport LVDS Clock signal(+)	
35	GND		
36	DIN3-	Dport (-)LVDS CH3 differential data input	
37	DIN3+	Dport (+)LVDS CH3 differential data input	
38	DIN4-	Dport (-)LVDS CH4 differential data input	
39	DIN4+	Dport (+)LVDS CH4 differential data input	
40	GND		
41	GND		

[Note] GND of a liquid crystal panel drive part has connected with a module chassis.

[Note 1] The equivalent circuit figure of the terminal

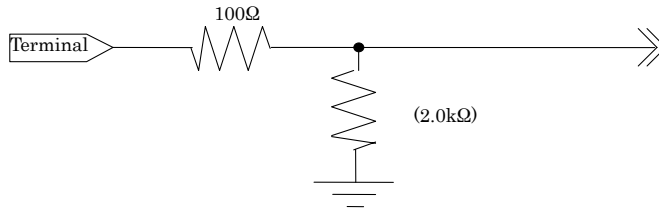

[Note 2] LVDS Data order

SELLVDS		
Data	L(GND) or Open [VESA]	H(3.3V) [JEIDA]
TA0	R0(LSB)	R4
TA1	R1	R5
TA2	R2	R6
TA3	R3	R7
TA4	R4	R8
TA5	R5	R9(MSB)
TA6	G0(LSB)	G4
TB0	G1	G5
TB1	G2	G6
TB2	G3	G7
TB3	G4	G8
TB4	G5	G9(MSB)
TB5	B0(LSB)	B4
TB6	B1	B5
TC0	B2	B6
TC1	B3	B7
TC2	B4	B8
TC3	B5	B9(MSB)
TC4	NA	NA
TC5	NA	NA
TC6	DE(*)	DE(*)
TD0	R6	R2
TD1	R7	R3
TD2	G6	G2
TD3	G7	G3
TD4	B6	B2
TD5	B7	B3
TD6	N/A	N/A
TE0	R8	R0(LSB)
TE1	R9(MSB)	R1
TE2	G8	G0(LSB)
TE3	G9(MSB)	G1
TE4	B8	B0(LSB)
TE5	B9(MSB)	B1
TE6	N/A	N/A

NA: Not Available

(*) Since the display position is prescribed by the rise of DE(Display Enable) signal, please do not fix DE signal during operation at "High".

SELLVDS= Low (GND) or OPEN

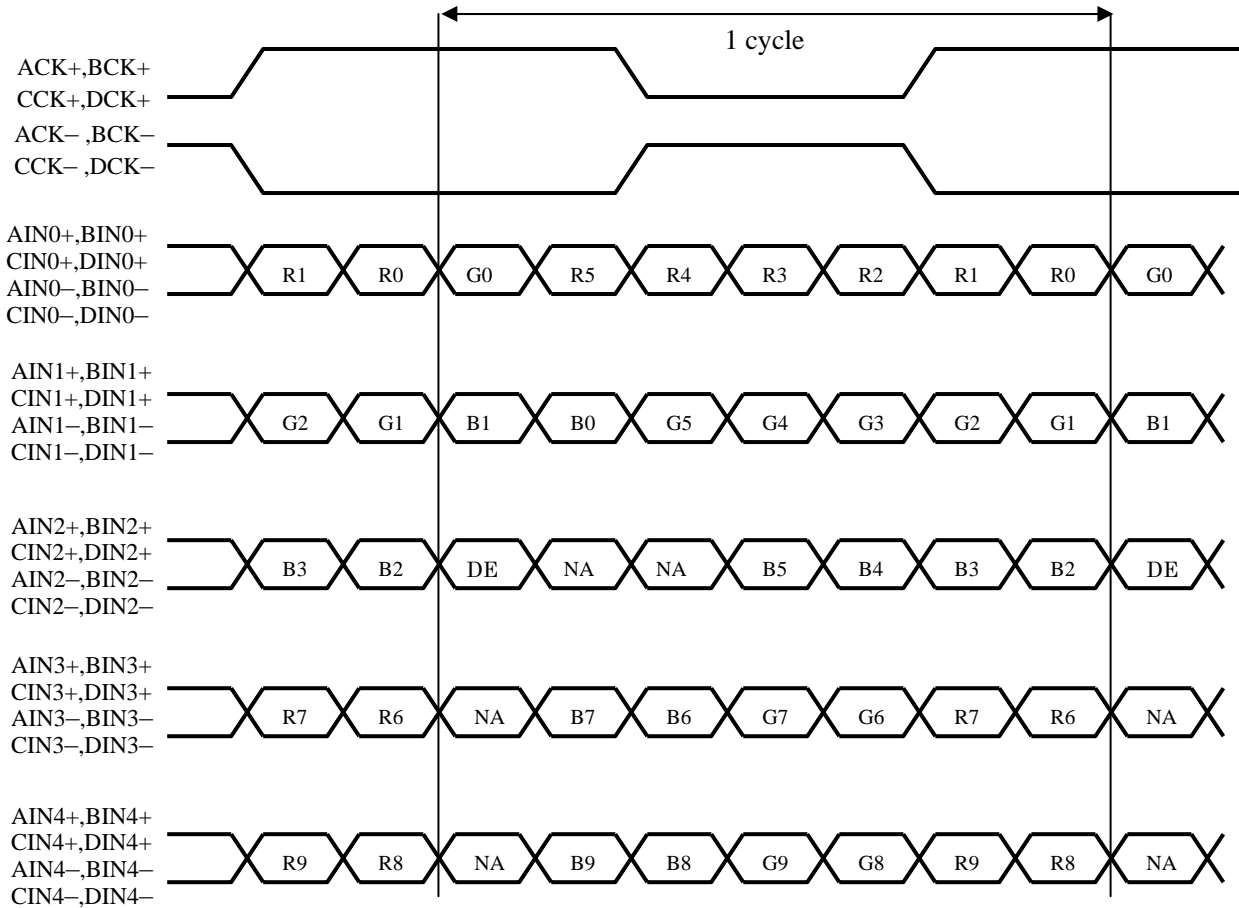

SELLVDS= High (3.3V)

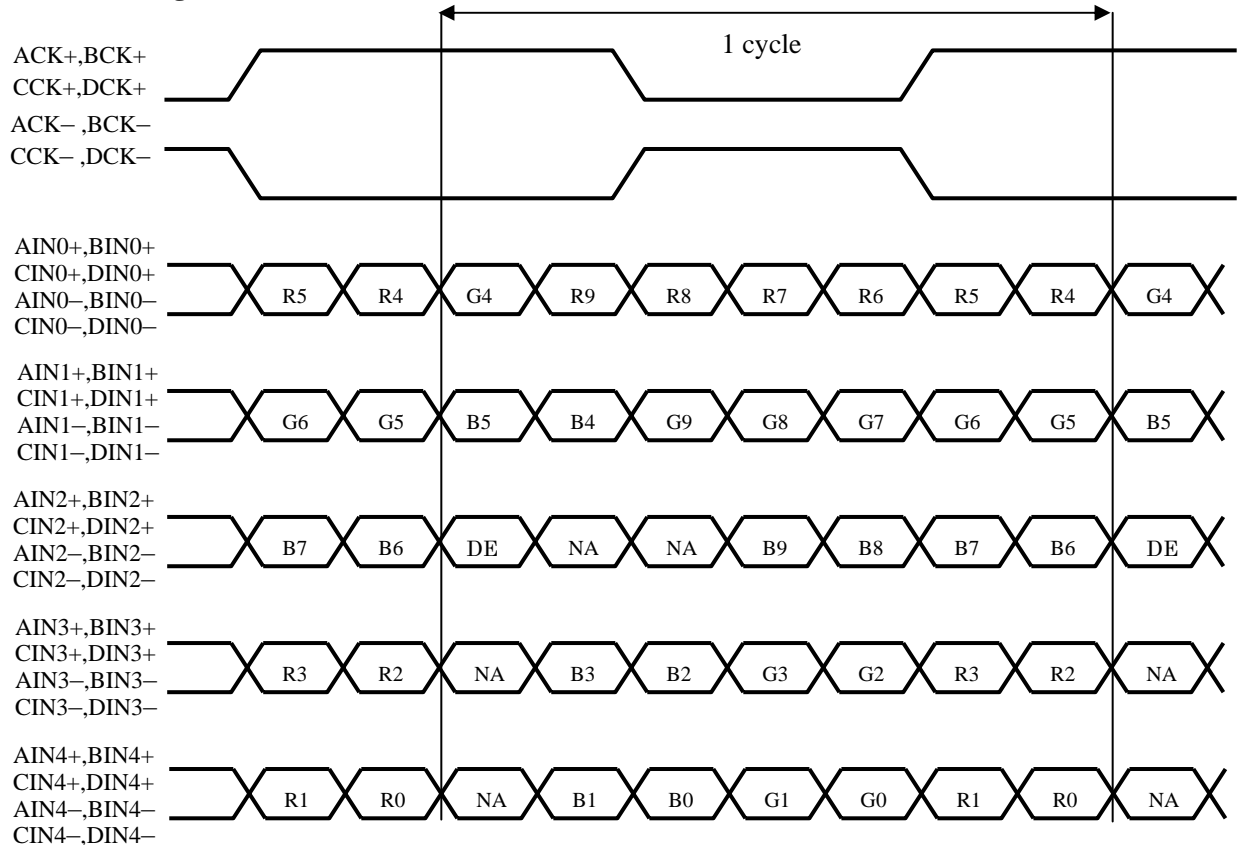

DE: Display Enable, NA: Not Available (Fixed Low)

[Note 3] The equivalent circuit figure of the terminal

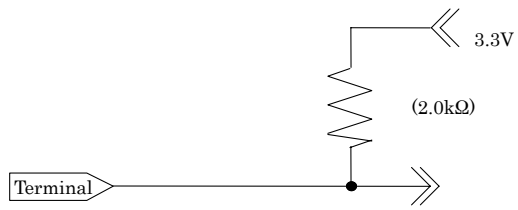

[Note 4] Display reversal function

R/L : H(3.3V) U/D: H (3.3V)

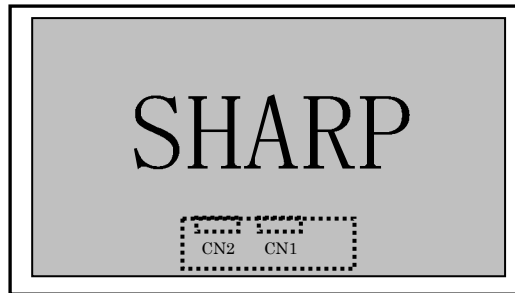

4.2. Interface block diagram

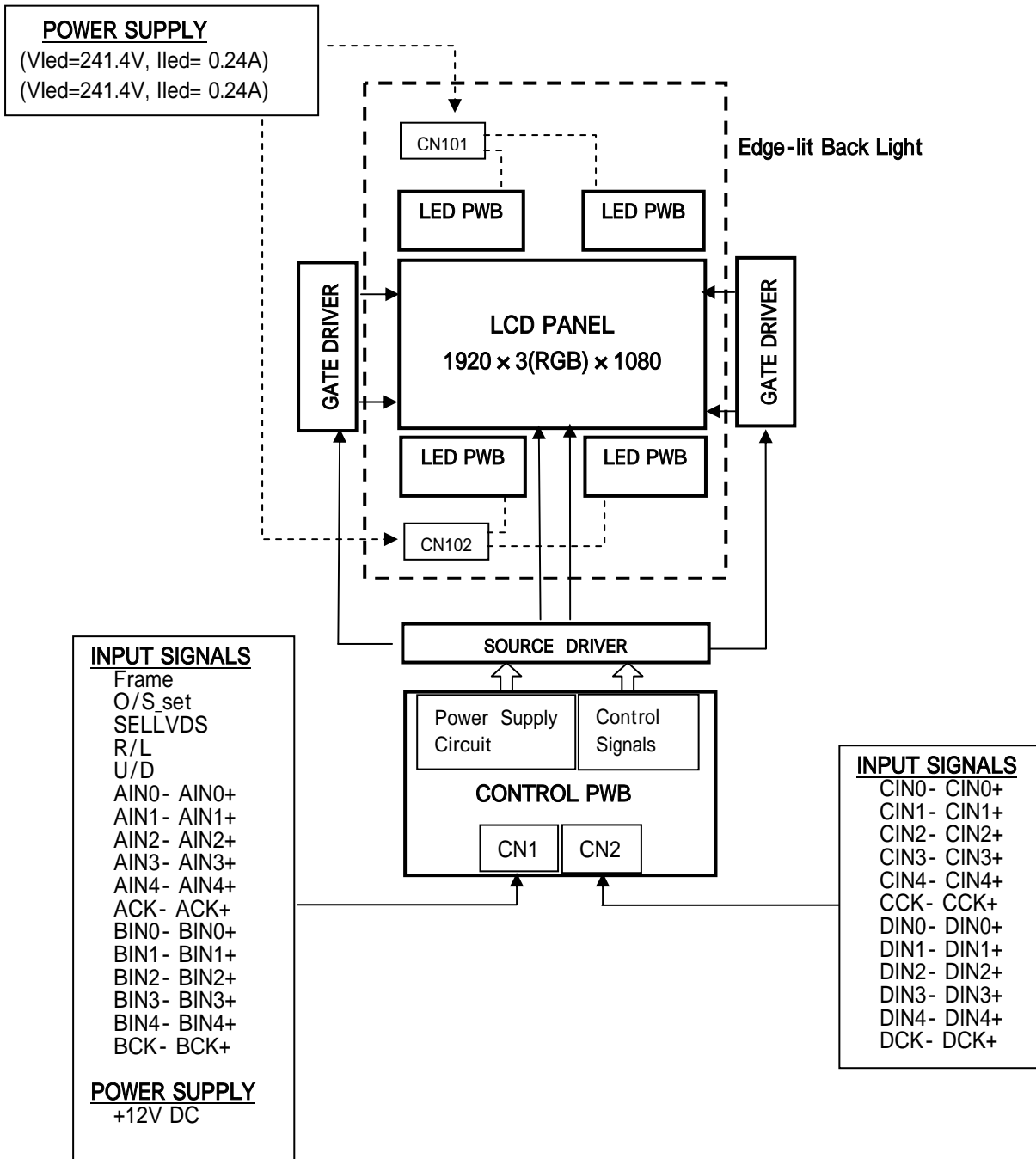

4.3 Backlight driving

CN101, CN102 (DC power supply)

Using connector: 51103-0600 (Molex)

Matching connector: 53375-0610 (Molex)

Pin No.	Symbol	Function	Remark
1	PIN_1	LED Cathode terminal	
2	Reserved		
3	PIN_3	LED Cathode terminal	
4	Reserved		
5	PIN_5	LED Anode terminal	
6	PIN_6	LED Anode terminal	

CN101 side cable lengths (from Panel backplate opening to including connector head) L=320mm(typ)

CN102 side cable lengths (from Panel backplate opening to including connector head) L=350mm(typ)

* Equivalent Circuit of LED PWB (This circuit is common in both side.)

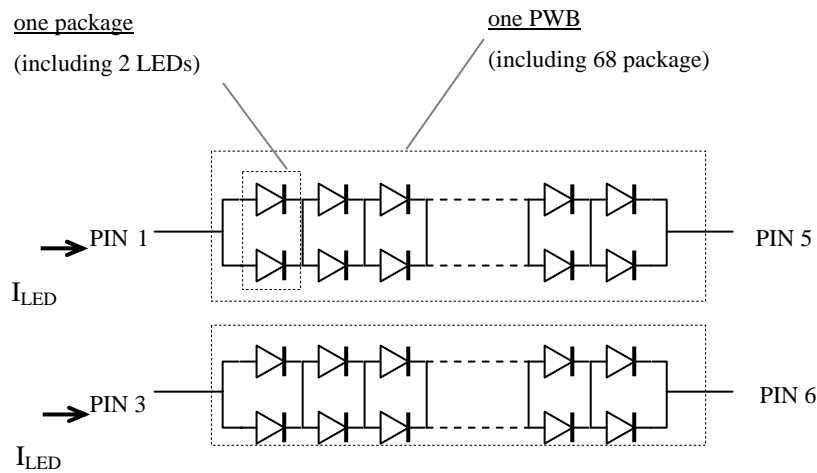

4.4 The back light system characteristics

The back light system is side-edge-lit type with LED. (Die/package: 2/ 68package)

The characteristics of the LED are shown in the following table.

Item	Symbol	Min.	Typ.	Max.	Unit	Remarks
Life time	T_{LED}	30000	50000	-	Hour	[Note]

[Note] LED life time is defined as the time when brightness becomes 50% of the original value in the continuous operation.

[Operation condition]

ambient temperature $T_a=25$,

$I_F = 0.120A$ (each LED PWB), using heat radiation system on the backside module

* Under such a condition, please keep 85.0 or less the temperature of the terminal of LED.

5. Absolute Maximum Ratings

Parameter	Symbol	Condition	Ratings	Unit	Remark
Input voltage (for Control PWB)	V _I	Ta=25 °C	-0.3 ~ 3.6	V	[Note 1]
12V supply voltage (for Control PWB)	VCC	Ta=25 °C	0 ~ +14	V	
Reverse voltage for LED-PWB	V _{LED}	Ta=25 °C	5	V	Each LED 1 piece
Forward Current for LED-PWB	I _{LED}	Ta=25 °C	150	mA	[Note 3]
Reverse Current for LED-PWB	I _{LED}	Ta=25 °C	10	μA	[Note 3]
Storage temperature	Tstg	-	-25 ~ +60	°C	[Note 2]
Operation temperature (Ambient)	Topa	-	0 ~ +50	°C	

[Note 1] SELLVDS, FRAME, O/S_set, R/L, U/D

[Note 2] Humidity 95%RH Max.(Ta 40°C)

Maximum wet-bulb temperature at 39 °C or less.(Ta>40°C)

No condensation.

[Note 3] PIN1, PIN3 (CN101, CN102)

6. Electrical Characteristics

6.1. Control circuit driving

Ta=25 °C

Parameter		Symbol	Min.	Typ.	Max.	Unit	Remark
+12V supply voltage	Supply voltage	V _{CC}	11.4	12	12.6	V	[Note 1]
	Current dissipation	I _{CC}	-	0.5	1.8	A	[Note 2]
	Inrush current	I _{RUSH}	-	3.0	5.0	A	t1=1ms [Note 7]
Permissible input ripple voltage		V _{RP}	-	-	100	mV _{P-P}	V _{CC} = +12.0V
Differential input threshold voltage	High	V _{TH}	-	-	100	mV	V _{CM} = +1.2V [Note 6]
	Low	V _{TL}	-100	-	-	mV	
Input Low voltage		V _{IL}	0	-	1.0	V	[Note 3]
Input High voltage		V _{IH}	2.3	-	3.3	V	
Input leak current (Low)		I _{IL1}	-	-	400	μA	V _I = 0V [Note 4]
		I _{IL2}	-	-	40	μA	V _I = 0V [Note 5]
Input leak current (High)		I _{IH1}	-	-	40	μA	V _I = 3.3V [Note 4]
		I _{IH2}	-	-	400	μA	V _I = 3.3V [Note 5]
Terminal resistor		R _T	-	100	-	Ω	Differential input

[Note] V_{CM}: Common mode voltage of LVDS driver.

[Note 1]

Input voltage sequences

0 < t1	20ms
10 < t2	20ms
10 < t3	50ms
0 < t4	1s
t5	1s
t6	0
t7	300ms

Dip conditions for supply voltage

- a) 6.5V V_{CC} < 10.8V
- td 10ms
- b) V_{CC} < 6.5V

Dip conditions for supply voltage is based on input voltage sequence.

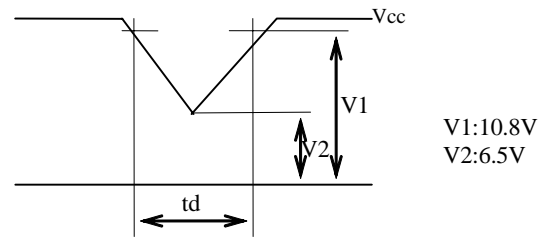
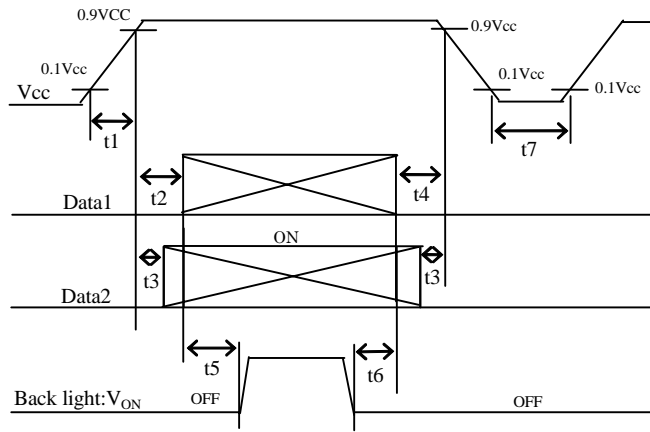

Data1: ACK±, AIN0±, AIN1±, AIN2±, AIN3±, AIN4±, BCK±, BIN0±, BIN1±, BIN2±, BIN3±, BIN4±

*V_{CM} voltage pursues the sequence mentioned above

Data2: SELLVDS, FRAME, O/S_SET, R/L, U/D

[Note] About the relation between data input and back light lighting, please base on the above-mentioned input sequence. When back light is switched on before panel operation or after a panel operation stop, it may not display normally. But this phenomenon is not based on change of an incoming signal, and does not give damage to a liquid crystal display.

[Note 2] Typical current situation: 1024 gray-bar patterns. (V_{cc} = +12.0V)

The explanation of RGB gray scale is seen in section 8.

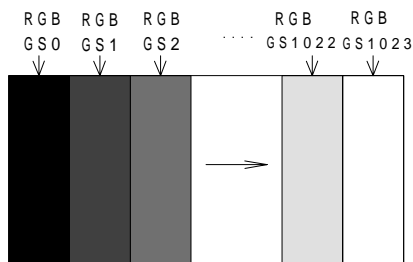

V_{cc} = +12.0V
 CK = 74.25MHz
 Th = 7.41μs

[Note 3] SELLVDS, FRAME, O/S_SET, R/L, U/D

[Note 4] O/S_SET

[Note 5] FRAME, SELLVDS

[Note 6] ACK±, AIN0±, AIN1±, AIN2±, AIN3±, AIN4±, BCK±, BIN0±, BIN1±, BIN2±, BIN3±, BIN4±

[Note 7] V_{cc}12V inrush current waveform (This figure is I_{RUSH} : t₁=1ms)

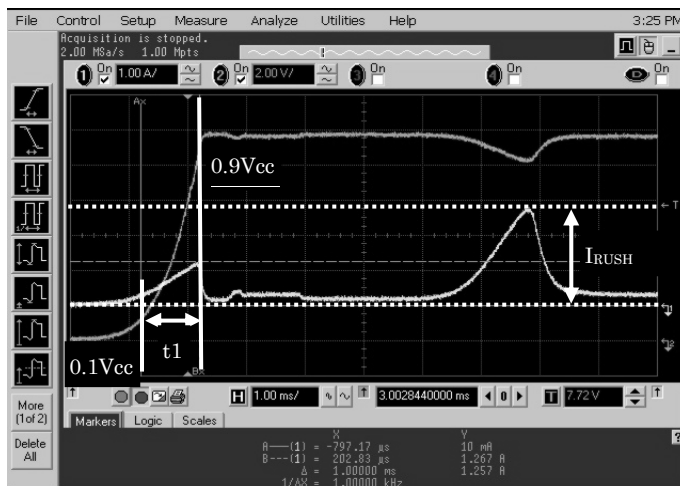

6.2. LED driving for back light

Ta=25

Parameter	Symbol	Min.	Typ.	Max.	Unit	Remark
LED Current	I_{LED}	112.8	120	127.2	mA	The value of each bar [Note 1]
LED Voltage	V_F	227.0	241.4	255.8	V	$I_{LED}=120mA$ [Note2]
PWM dimming frequency	f_{PWM}	95	-	370	Hz	
PWM dimming on duty	PWM duty	10	-	100	%	

[Note1] PIN1, PIN3 (CN101, CN102)

*Please decrease LED heat enough when the LED current is increased more than TYP value.
please keep 85.0 or less the temperature of the terminal of LED.

[Note2] $T_a = 25$, Measurement after 100ms has passed since power supply was turned on.

*The products are sensitive to the static electricity and care shall be fully taken when handling the products. Particularly in case that an over-voltage which exceeds the Absolute Maximum Rating of the products shall be applied, the overflowed energy may cause damages to, or possibly result in destruction of the products. Please take absolutely secured countermeasures against static electricity and surge when handling the products.

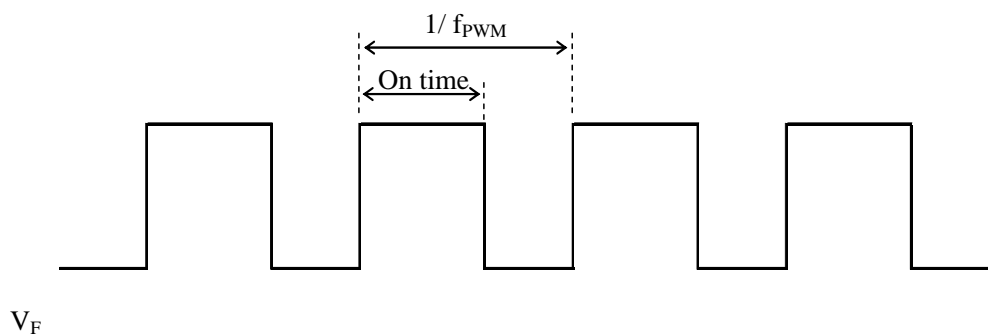

Fig.1 LED Backlight PWM0

7 Timing characteristics of input signals

Timing characteristics

Timing diagrams of input signal are shown in Fig.2.

Parameter		Symbol	Min.	Typ.	Max.	Unit	Remark
Clock	Frequency	1/Tc	55	74.25	80	MHz	
Data enable signal	Horizontal period	TH	515	550	825	Clock	
			7.1	7.41	11.1	µs	
	Horizontal period (High)	THd	480	480	480	Clock	
	Vertical period	TV	1120	1125	1400	Line	
			73.052	120	120.64	Hz	
Vertical period (High)	TVd	1080	1080	1080	line		

[Note]-When vertical period is very long, flicker and etc. may occur.

- Please turn off the module after it shows the black screen.
- Please make sure that length of vertical period should become of an integral multiple of horizontal length of period. Otherwise, the screen may not display properly.
- As for your final setting of driving timing, we will conduct operation check test at our side, please inform your final setting.

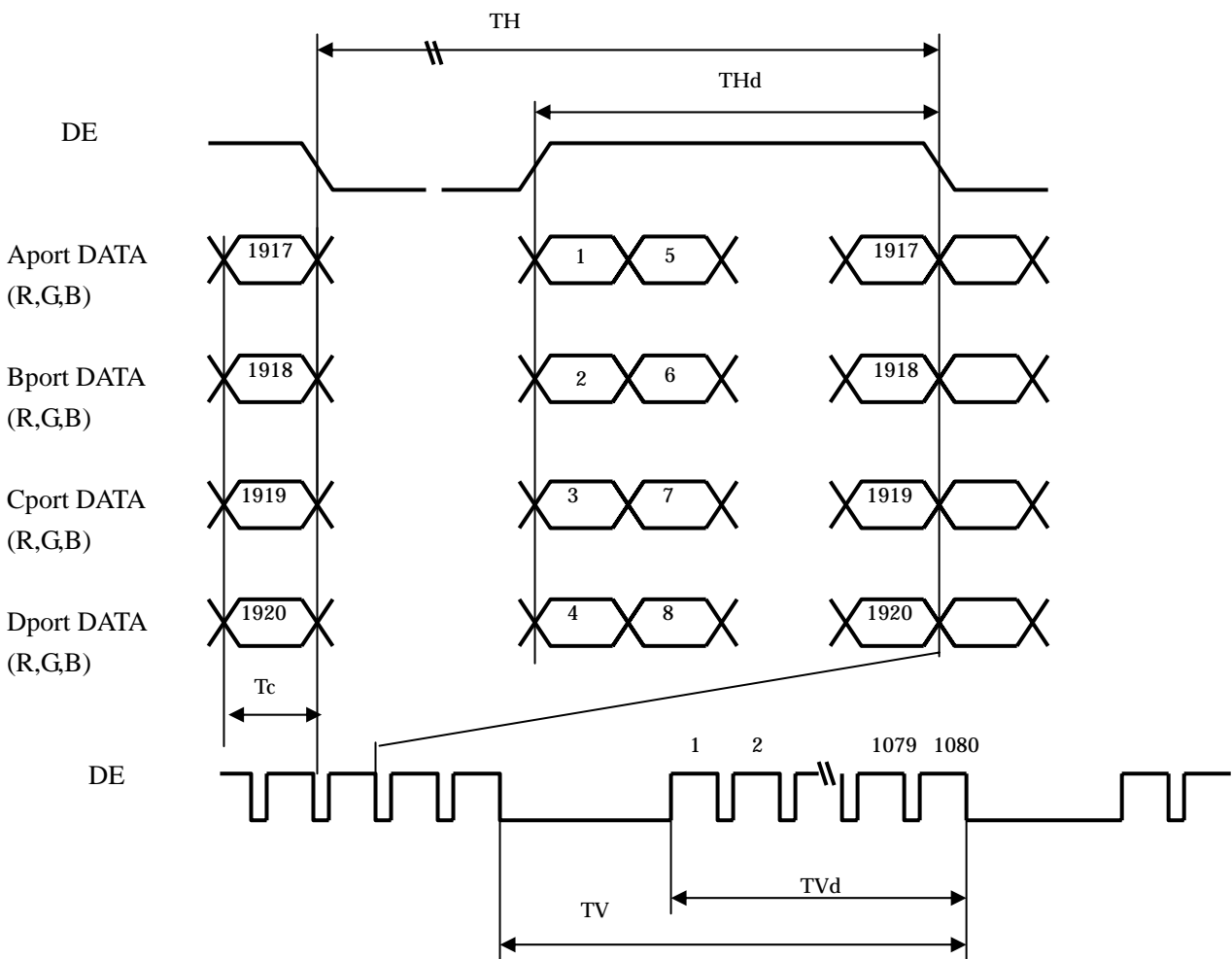

Fig.2 Timing characteristics of input signals

LVDS DC Specifications

Symbol	Parameter	Condition	min	typ	max	units
Vod	Differential voltage	RL=100	200	400	600	mV
Voc	Common mode voltage	RL=100Ω	Vod/2	1200	2.4·Vod/2	mV

LVDS AC Specifications

Symbol	Parameter	min	min	min	units
tCLK	LVDS clock period	12.50	13.47	18.18	ns
tpd0	LVDS data posotion0	-0.25	0	+0.25	ns
tpd1	LVDS data posotion1	1/7 x tCLK - 0.25	1/7 x tCLK	1/7 x tCLK + 0.25	ns
tpd2	LVDS data posotion2	2/7 x tCLK - 0.25	2/7 x tCLK	2/7 x tCLK + 0.25	ns
tpd3	LVDS data posotion3	3/7 x tCLK - 0.25	3/7 x tCLK	3/7 x tCLK + 0.25	ns
tpd4	LVDS data posotion4	4/7 x tCLK - 0.25	4/7 x tCLK	4/7 x tCLK + 0.25	ns
tpd5	LVDS data posotion5	5/7 x tCLK - 0.25	5/7 x tCLK	5/7 x tCLK + 0.25	ns
tpd6	LVDS data posotion6	6/7 x tCLK - 0.25	6/7 x tCLK	6/7 x tCLK + 0.25	ns

LVDS DC & AC Specifications

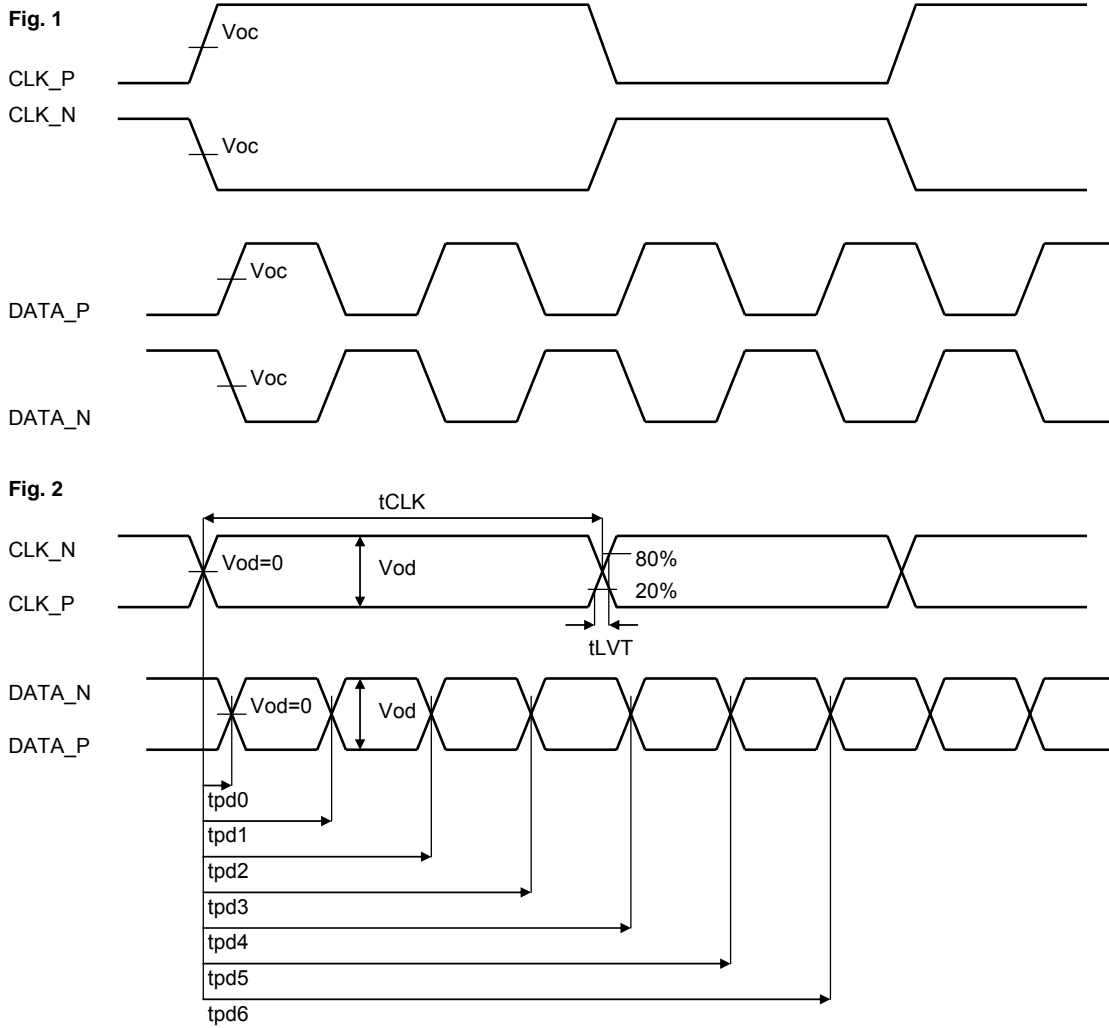

Input data signal and display position on the screen

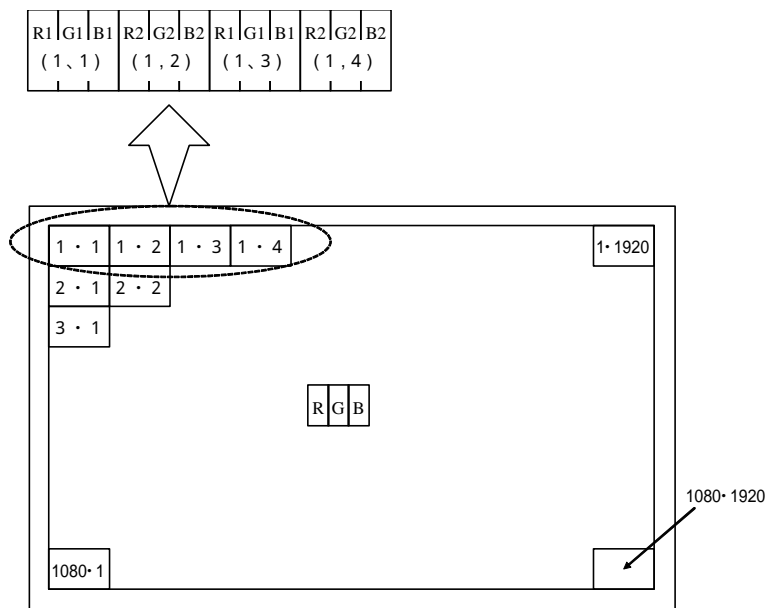

Display position of Dat (V,H)

8 Input Signal, Basic Display Colors and Gray Scale of Each Color

Colors & Gray scale	Data signal																															
	Gray Scale	R0	R1	R2	R3	R4	R5	R6	R7	R8	R9	G0	G1	G2	G3	G4	G5	G6	G7	G8	G9	B0	B1	B2	B3	B4	B5	B6	B7	B8	B9	
Basic Color	Black	–	0	0	0	0	0	0	0	0	0	0	0	0	0	0	0	0	0	0	0	0	0	0	0	0	0	0	0	0	0	0
	Blue	–	0	0	0	0	0	0	0	0	0	0	0	0	0	0	0	0	0	0	0	0	1	1	1	1	1	1	1	1	1	1
	Green	–	0	0	0	0	0	0	0	0	0	1	1	1	1	1	1	1	1	1	1	1	0	0	0	0	0	0	0	0	0	0
	Cyan	–	0	0	0	0	0	0	0	0	0	1	1	1	1	1	1	1	1	1	1	1	1	1	1	1	1	1	1	1	1	1
	Red	–	1	1	1	1	1	1	1	1	1	0	0	0	0	0	0	0	0	0	0	0	0	0	0	0	0	0	0	0	0	0
	Magenta	–	1	1	1	1	1	1	1	1	1	0	0	0	0	0	0	0	0	0	0	0	1	1	1	1	1	1	1	1	1	1
	Yellow	–	1	1	1	1	1	1	1	1	1	1	1	1	1	1	1	1	1	1	1	1	0	0	0	0	0	0	0	0	0	0
	White	–	1	1	1	1	1	1	1	1	1	1	1	1	1	1	1	1	1	1	1	1	1	1	1	1	1	1	1	1	1	1
Gray Scale of Red	Black	GS0	0	0	0	0	0	0	0	0	0	0	0	0	0	0	0	0	0	0	0	0	0	0	0	0	0	0	0	0	0	
	↑	GS1	1	0	0	0	0	0	0	0	0	0	0	0	0	0	0	0	0	0	0	0	0	0	0	0	0	0	0	0	0	
	Darker	GS2	0	1	0	0	0	0	0	0	0	0	0	0	0	0	0	0	0	0	0	0	0	0	0	0	0	0	0	0	0	
	↑	↓																														
	↓	↓																														
	Brighter	GS1021	1	0	1	1	1	1	1	1	1	0	0	0	0	0	0	0	0	0	0	0	0	0	0	0	0	0	0	0	0	
	↓	GS1022	0	1	1	1	1	1	1	1	1	0	0	0	0	0	0	0	0	0	0	0	0	0	0	0	0	0	0	0	0	
	Red	GS1023	1	1	1	1	1	1	1	1	1	0	0	0	0	0	0	0	0	0	0	0	0	0	0	0	0	0	0	0	0	
Gray Scale of Green	Black	GS0	0	0	0	0	0	0	0	0	0	0	0	0	0	0	0	0	0	0	0	0	0	0	0	0	0	0	0	0	0	
	↑	GS1	0	0	0	0	0	0	0	0	0	1	0	0	0	0	0	0	0	0	0	0	0	0	0	0	0	0	0	0	0	
	Darker	GS2	0	0	0	0	0	0	0	0	0	0	1	0	0	0	0	0	0	0	0	0	0	0	0	0	0	0	0	0	0	
	↑	↓																														
	↓	↓																														
	Brighter	GS1021	0	0	0	0	0	0	0	0	0	1	0	1	1	1	1	1	1	1	1	0	0	0	0	0	0	0	0	0	0	
	↓	GS1022	0	0	0	0	0	0	0	0	0	0	1	1	1	1	1	1	1	1	1	0	0	0	0	0	0	0	0	0	0	
	Green	GS1023	0	0	0	0	0	0	0	0	0	1	1	1	1	1	1	1	1	1	1	0	0	0	0	0	0	0	0	0	0	
Gray Scale of Blue	Black	GS0	0	0	0	0	0	0	0	0	0	0	0	0	0	0	0	0	0	0	0	0	0	0	0	0	0	0	0	0	0	
	↑	GS1	0	0	0	0	0	0	0	0	0	0	0	0	0	0	0	0	0	0	0	1	0	0	0	0	0	0	0	0	0	
	Darker	GS2	0	0	0	0	0	0	0	0	0	0	0	0	0	0	0	0	0	0	0	0	1	0	0	0	0	0	0	0	0	
	↓	↓																														
	↓	↓																														
	Brighter	GS1021	0	0	0	0	0	0	0	0	0	0	0	0	0	0	0	0	0	0	0	1	0	1	1	1	1	1	1	1	1	
	↓	GS1022	0	0	0	0	0	0	0	0	0	0	0	0	0	0	0	0	0	0	0	0	1	1	1	1	1	1	1	1	1	
	Blue	GS1023	0	0	0	0	0	0	0	0	0	0	0	0	0	0	0	0	0	0	0	1	1	1	1	1	1	1	1	1	1	

0: Low level voltage, 1: High level voltage.

Each basic color can be displayed in 1024 gray scales from 10 bits data signals. According to the combination of total 30 bits data signals, one billion-color display can be achieved on the screen.

9 Optical characteristics

Ta=25°C, V_{CC}=12.0V, V_{LED}=(241.4V) frame rate:120Hz (typ.value)

Parameter		Symbol	Condition	Min.	Typ.	Max.	Unit	Remark
Viewing angle range	Horizontal	θ_{21} θ_{22}	CR 100	70	88	-	Deg.	[Note1,4]
	Vertical	θ_{11} θ_{12}		70	88	-	Deg.	
Contrast ratio		CRn	$\theta=0$ deg.	3750	5000	-		[Note2,4]
Response time		τ_{DRV}		-	6	8	ms	[Note3,4,5]
Chromaticity	White	x		0.248	0.278	0.308	-	I _{LED} =0.12A [Note4]
		y		0.255	0.285	0.315	-	
	Red	x		0.618	0.648	0.678	-	
		y		0.311	0.341	0.371	-	
	Green	x		0.271	0.301	0.331	-	
		y		0.614	0.644	0.674	-	
Blue	x	0.118		0.148	0.178	-		
	y	0.034		0.064	0.094	-		
Luminance	White	Y _L	400	450	-	cd/m ²		
Luminance uniformity	White	δw			1.25		[Note 6]	
	Black	δb			1.75		[Note 6]	

Measurement condition

*The measurement shall be executed 60 minutes after lighting at rating.

[Note]The optical characteristics are measured using the following equipment.

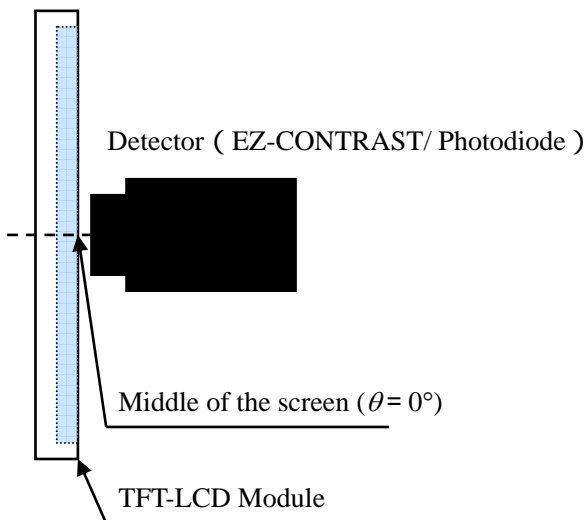

Fig.4-1 Measurement of viewing angle range and Response time.

Viewing angle range: EZ-CONTRAST

Response time: Photodiode

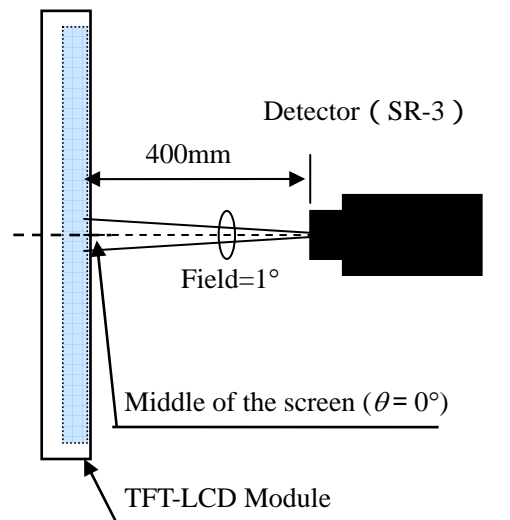
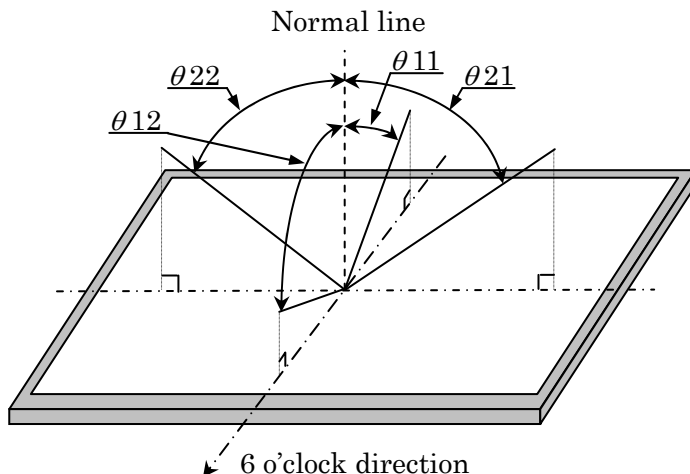

Fig.4-2 Measurement of Contrast, Luminance, Chromaticity.

[Note 1]Definitions of viewing angle range :



[Note 2]Definition of contrast ratio :

The contrast ratio is defined as the following.

$$\text{Contrast Ratio} = \frac{\text{Luminance (brightness) with all pixels white}}{\text{Luminance (brightness) with all pixels black}}$$

[Note 3]Definition of response time

The response time (T_{DRV}) is defined as the following figure and shall be measured by switching the input signal for “any level of gray (0%, 25%, 50%, 75% and 100%)” and “any level of gray (0%, 25%, 50%, 75% and 100%)”.

	0%	25%	50%	75%	100%
0%		tr:0%-25%	tr:0%-50%	tr:0%-75%	tr:0%-100%
25%	td: 25%-0%		tr: 25%-50%	tr:25%-75%	tr: 25%-100%
50%	td: 50%-0%	td: 50%-25%		tr: 50%-75%	tr: 50%-100%
75%	td: 75%-0%	td: 75%-25%	td: 75%-50%		tr: 75%-100%
100%	td: 100%-0%	td: 100%-25%	td: 100%-50%	td:100%-75%	

t*:x-y...response time from level of gray(x) to level of gray(y)

$$\tau_{DRV} = \Sigma(t^*:x-y)/20$$

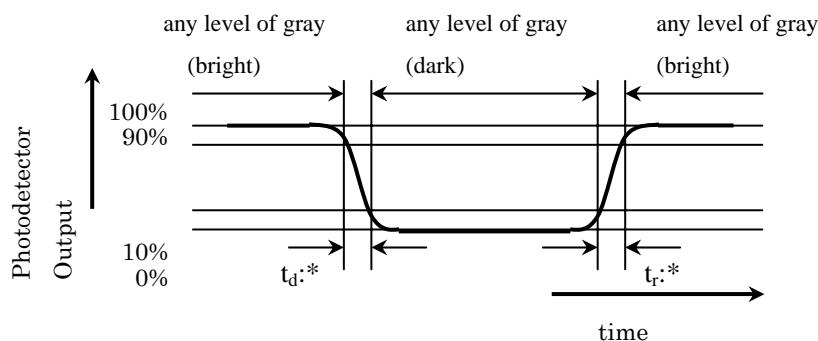

[Note 4]This shall be measured at center of the screen.

[Note 5] This value is valid when O/S driving is used at typical input time value.

[Note 6] Definition of white uniformity ;

White uniformity is defined as the following with five measurements. (A~E)

$$\delta w = \frac{\text{Maximum luminance of five points (brightness)}}{\text{Minimum luminance of five points (brightness)}}$$

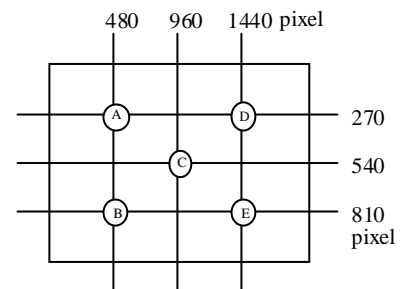

10 Precautions

10.1. Fail safe design

LCD Module has an inherent chance of failure. Customers must protect against injury, damage or loss from such failures by incorporating safety design measures into your facility and equipment such as redundancy, fire protection, and prevention of over-current levels and other abnormal operating conditions.

10.2. Handling Precautions of the module

- a) Be sure to turn off the power supply when inserting or disconnecting the cable.
- b) Be sure to design the cabinet so that the module can be installed without any extra stress such as warp or twist.
- c) Since the front polarizer is easily damaged, pay attention not to scratch it.
- d) Since long contact with water may cause discoloration or spots, wipe off water drop immediately.
- e) When the panel surface is soiled, wipe it with absorbent cotton or other soft cloth.
- f) Since the panel is made of glass, it may break or crack if dropped or bumped on hard surface. Handle with care.
- g) Since CMOS LSI is used in this module, take care of static electricity and take the human earth into consideration when handling.
- h) The module has some printed circuit boards (PCBs) on the back side, take care to keep them from any stress or pressure when handling or installing the module; otherwise some of electronic parts on the PCBs may be damaged.
- i) Observe all other precautionary requirements in handling components.
- j) When some pressure is added onto the module from rear side constantly, it causes display non-uniformity issue, functional defect, etc. So, please avoid such design.
- k) When giving a touch to the panel at power on supply, it may cause some kinds of degradation. In that case, once turn off the power supply, and turn on after several seconds again, and that is disappear.
- l) When handling LCD modules and assembling them into cabinets, please be noted that long-term storage in the environment of oxidization or deoxidization gas and the use of such materials as reagent, solvent, adhesive, resin, etc. which generate these gasses, may cause corrosion and discoloration of the LCD modules.
- m) This LCD module is designed to prevent dust from entering into it. However, there would be a possibility to have a bad effect on display performance in case of having dust inside of LCD module. Therefore, please ensure to design your TV set to keep dust away around LCD module.

11 Packing form

- a) Piling number of cartons : 4 maximum
 b) Packing quantity in one carton : 16 pcs
 c) Carton size : 1195(W) × 1140(H) × 834(D)mm
 d) Total mass of one carton filled with full modules : 193.7kg

12 Reliability test item

No.	Test item	Condition
1	High temperature storage test	Ta=60°C 240h
2	Low temperature storage test	Ta=-25°C 240h
3	High temperature and high humidity operation test	Ta=40°C ; 95%RH 240h (No condensation)
4	High temperature operation test	Ta=50°C 240h
5	Low temperature operation test	Ta=0°C 240h
6	Vibration test (non-operation)	Frequency: 10~57Hz/Vibration width (one side): 0.075mm : 58~500Hz/Acceleration: 9.8 m/s ² Sweep time: 11 minutes Test period: 3 hours (1h for each direction of X, Y, Z)
7	Shock test (non-operation)	Maximum acceleration: (294m/s ²) Pulse width: 11ms, sinusoidal half wave Direction: +/-X, +/-Y, +/-Z, once for each direction.
8	ESD	* At the following conditions, it is a thing without incorrect operation and destruction. (1)Non-operation: Contact electric discharge ±10kV Non-contact electric discharge ±20kV (2)Operation Contact electric discharge ±8kV Non-contact electric discharge ±15kV Conditions: 150pF, 330ohm

[Result evaluation criteria]

Under the display quality test condition with normal operation state, there shall be no change, which may affect practical display function.

*For Shock test and Vibration test, the method of fixation is not guaranteed excluding the method written in the attached document: ” The reliability test form (shock test & vibration test)”

13 Others

The label that displays SHARP, product model (LK460D3LA63), a product number is stuck on the back of the module.

【LK460D3LA63】

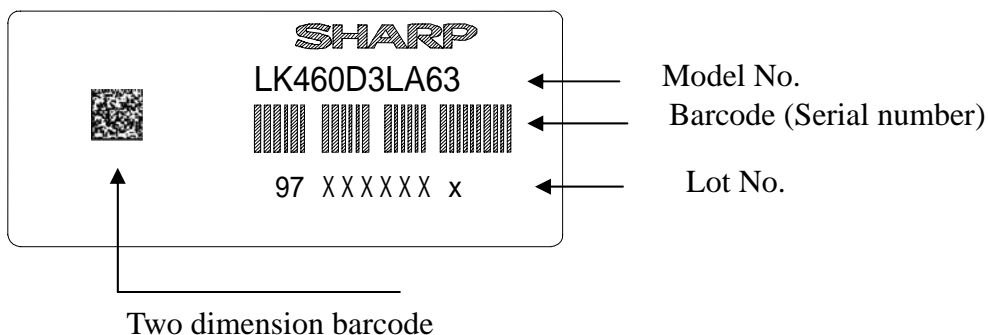

How to express Lot No.

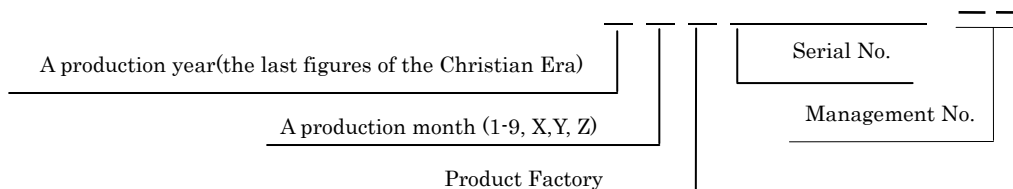

2) Packing Label

[LK460D3LA63]

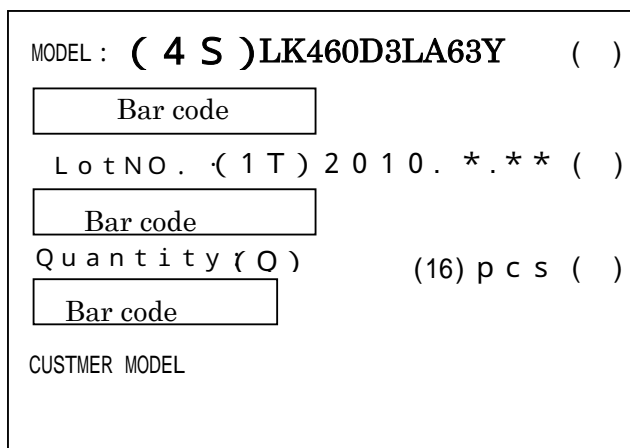

Management No
Lot No. (Date)
Quantity

- 3) Adjusting volume has been set optimally before shipment, so do not change any adjusted value.
If adjusted value is changed, the specification may not be satisfied.
- 4) Disassembling the module can cause permanent damage and should be strictly avoided.
- 5) Please be careful since image retention may occur when a fixed pattern is displayed for a long time.
- 6) The chemical compound, which causes the destruction of ozone layer, is not being used.
- 7) When any question or issue occurs, it shall be solved by mutual discussion.
- 8) This module is corresponded to RoHS.
- 9) Rust on the module is not taken up a problem

14 Carton storage condition

Temperature	0°C to 40°C
Humidity	95%RH or less
Reference condition	: 20°C to 35°C, 85%RH or less (summer) : 5°C to 15°C, 85%RH or less (winter) the total storage time (40°C,95%RH) : 240H or less
Sunlight	Be sure to shelter a product from the direct sunlight.
Atmosphere	Harmful gas, such as acid and alkali which bites electronic components and/or wires must not be detected.
Notes	Be sure to put cartons on palette or base, don't put it on floor, and store them with removing from wall Please take care of ventilation in storehouse and around cartons, and control changing temperature is within limits of natural environment
Storage life	1 year

LD-K22109_22

Parts Name	Material
Packing Case(Top)	Cardboard
Pack Ado(Bottom)	PS
Pack Ado(TopA)	PS
Pack Ado(TopB)	PS
Packing Case(Trunk frame)	Cardboard
Cardboard Prop	Cardboard
Plywood Palette	Plywoods
Fumigation Palette	Fumigationwoods
Antistatic Bag	PE (t=20μ)

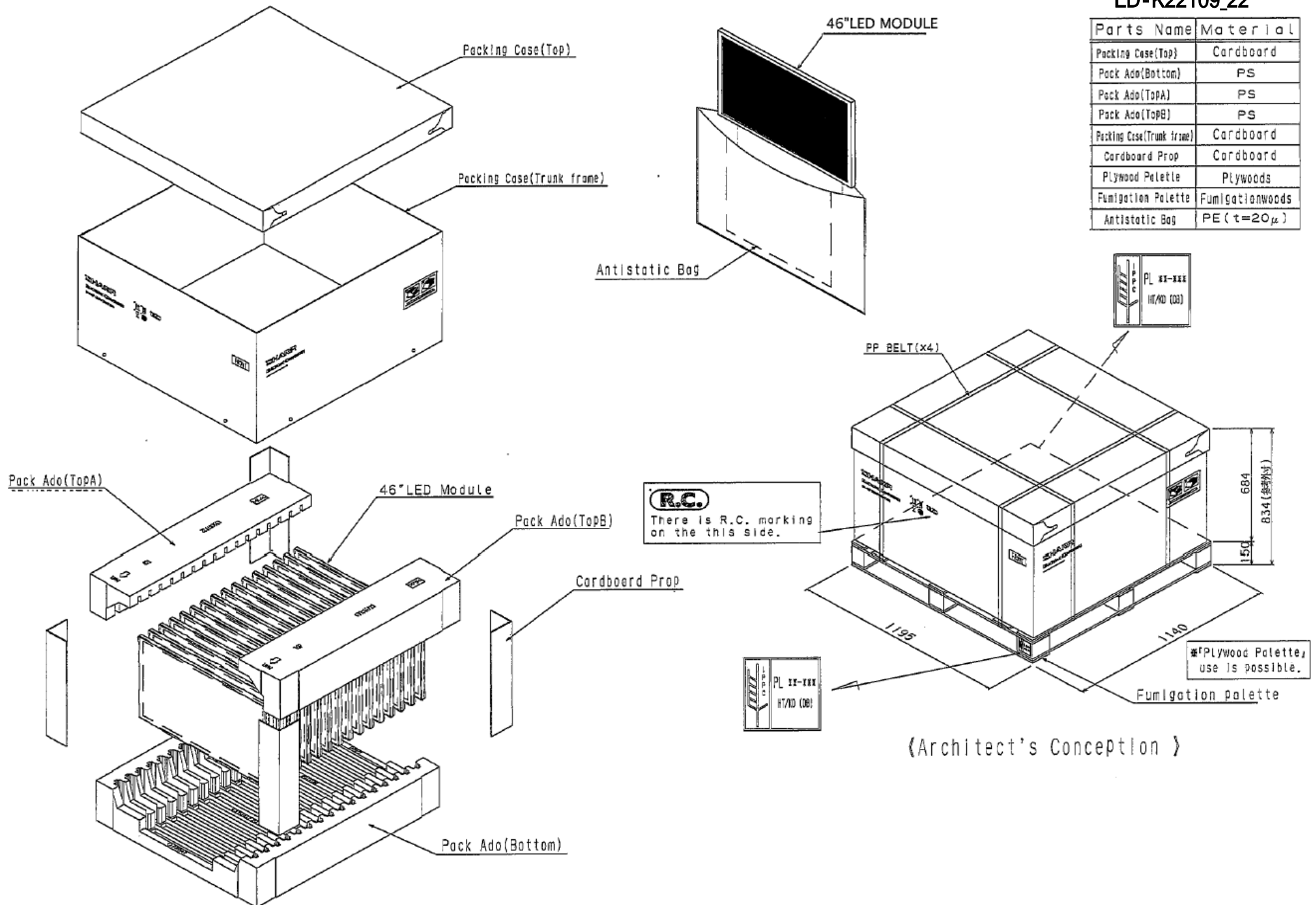

(Architect's Conception)

The reliability test form
(Shock test & Vibration test)

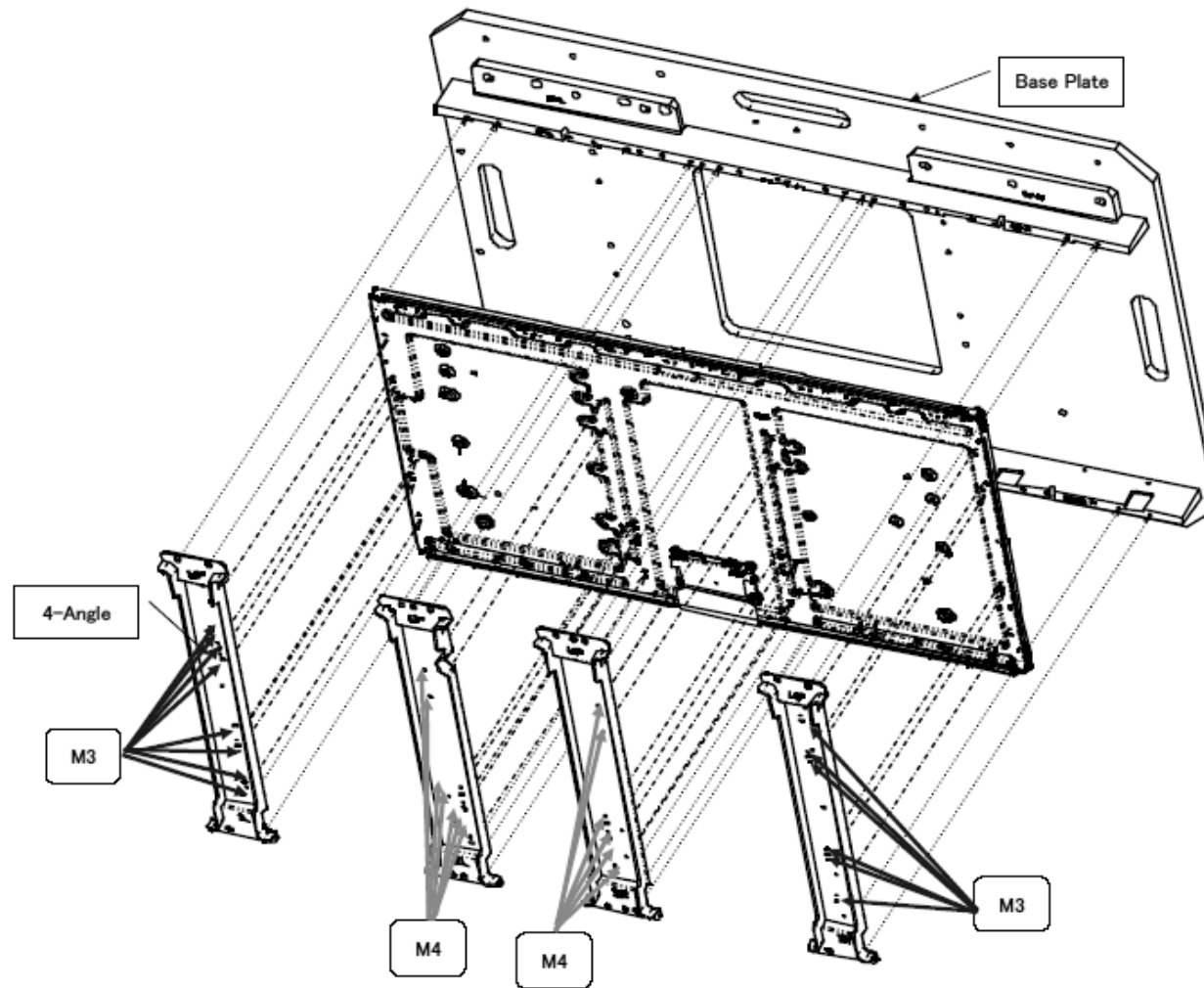

M4: 14 Places
M3: 14 Places