

SHARP

No.	LD-S10701
DATE	Sep.13, 2010

TENTATIVE

TECHNICAL LITERATURE
FOR
TFT - LCD module

MODEL No. LK601R3LA1x

The technical literature is subject to change without notice.
So, please contact SHARP or its representative before designing
your product based on this literature.

DEVELOPMENT DEPARTMENT 3
LIQUID CRYSTAL DISPLAY DIVISION 3
LIQUID CRYSTAL DISPLAY GROUP
SHARP CORPORATION

SHARP

TENTATIVE

No.	LD-S10701
DATE	Sep.13, 2010

TECHNICAL LITERATURE
FOR
TFT - LCD module

MODEL No. **LK601R3LA1x**

The technical literature is subject to change without notice.
So, please contact Sharp or its representative before designing
your product based on this literature.

英文技術資料確認印

確認欄

所属長	副参事	主事	主事	担当

ユーザー名: _____

1. Application

This technical literature applies to the color 60.1" TFT-LCD module LK601R3LA1x.

* These technical literature sheets are proprietary products of SHARP CORPORATION ("SHARP") and include materials protected under copyright of SHARP. Do not reproduce or cause any third party to reproduce them in any form or by any means, electronic or mechanical, for any purpose, in whole or in part, without the express written permission of SHARP.

* In case of using the device for applications such as control and safety equipment for transportation (aircraft, trains, automobiles, etc.), rescue and security equipment and various safety related equipment which require higher reliability and safety, take into consideration that appropriate measures such as fail-safe functions and redundant system design should be taken.

* Do not use the device for equipment that requires an extreme level of reliability, such as aerospace applications, telecommunication equipment (trunk lines), nuclear power control equipment and medical or other equipment for life support.

* SHARP assumes no responsibility for any damage resulting from the use of the device that does not comply with the instructions and the precautions specified in these technical literature sheets.

* Contact and consult with a SHARP sales representative for any questions about this device.

2. Overview

This module is a color active matrix LCD module incorporating amorphous silicon TFT (Thin Film Transistor). It is composed of a color TFT-LCD panel, driver ICs, control circuit, power supply circuit, and back light system etc. Graphics and texts can be displayed on a 3840 x RGB x 2160 (QFHD) dots panel with one billion colors by using LVDS (Low Voltage Differential Signaling) to interface, +12V of DC supply voltages.

This module also includes the LED PWB and LED DRIVER PWB to drive the LED.

And in order to improve the response time of LCD, this module applies the Over Shoot driving (O/S driving) technology for the control circuit. In the O/S driving technology, signals are being applied to the liquid crystal according to a pre-fixed process as an image signal of the present frame when a difference is found between image signal of the previous frame and that of the current frame after comparing them.

By using the captioned process, the image signals of this LCD module are being set so that image response can be completed within one frame, as a result, image blur can be improved and clear image performance can be realized.

3. Mechanical Specifications

Parameter	Specifications	Unit
Display size (Diagonal)	1526.630	mm
	60.1	inch
Active area	1330.56 (H) x 748.44 (V)	mm
Pixel Format	3840 (H) x 2160 (V) (1pixel = R + G + B dot)	pixel
Pixel pitch	0.3465(H) x 0.3465 (V)	mm
Pixel configuration	R, G, B horizontal stripe	
Display mode	Normally black	
Unit Outline Dimensions (*1)	1380[W] x 790 [H] x (116.6) [D]	mm
Mass	(27) ±1.0	kg
Surface treatment	Anti glare, low reflection coating Hard coating: 3H	

(*1) Outline dimensions are shown in Fig.1.

4. Input Terminals

4-1. TFT panel driving

CN1,CN2 (Interface signals) ※Shown in Fig.1

Using connector: FI-RE51S-HF (Japan Aviation Electronics Industry, Ltd.)

Mating connector: FI-RE51HL, FI-RE51CL, FI-RE51HLS (Japan Aviation Electronics Industry, Ltd.)

Mating LVDS transmitter : THC63LVD1023B (THine) or equivalent device

CN1

Pin No.	Symbol	Function	Remark
1	GND		
2	EIN0-	E port (-)LVDS CH0 differential data input	
3	EIN0+	E port (+)LVDS CH0 differential data input	
4	EIN1-	E port (-)LVDS CH1 differential data input	
5	EIN1+	E port (+)LVDS CH1 differential data input	
6	EIN2-	E port (-)LVDS CH2 differential data input	
7	EIN2+	E port (+)LVDS CH2 differential data input	
8	ECK-	E port LVDS Clock signal(-)	
9	ECK+	E port LVDS Clock signal(+)	
10	EIN3-	E port (-)LVDS CH3 differential data input	
11	EIN3+	E port (+)LVDS CH3 differential data input	
12	EIN4-	E port (-)LVDS CH4 differential data input	
13	EIN4+	E port (+)LVDS CH4 differential data input	
14	FIN0-	F port (-)LVDS CH0 differential data input	
15	FIN0+	F port (+)LVDS CH0 differential data input	
16	FIN1-	F port (-)LVDS CH1 differential data input	
17	FIN1+	F port (+)LVDS CH1 differential data input	
18	FIN2-	F port (-)LVDS CH2 differential data input	
19	FIN2+	F port (+)LVDS CH2 differential data input	
20	FCK-	F port LVDS Clock signal(-)	
21	FCK+	F port LVDS Clock signal(+)	
22	FIN3-	F port (-)LVDS CH3 differential data input	
23	FIN3+	F port (+)LVDS CH3 differential data input	
24	FIN4-	F port (-)LVDS CH4 differential data input	
25	FIN4+	F port (+)LVDS CH4 differential data input	
26	GND		
27	GIN0-	Port (-)LVDS CH0 differential data input	
28	GIN0+	G port (+)LVDS CH0 differential data input	
29	GIN1-	G port (-)LVDS CH1 differential data input	
30	GIN1+	G port (+)LVDS CH1 differential data input	
31	GIN2-	G port (-)LVDS CH2 differential data input	
32	GIN2+	G port (+)LVDS CH2 differential data input	
33	GCK-	G port LVDS Clock signal(-)	
34	GCK+	G port LVDS Clock signal(+)	
35	GIN3-	G port (-)LVDS CH3 differential data input	
36	GIN3+	G port (+)LVDS CH3 differential data input	
37	GIN4-	G port (-)LVDS CH4 differential data input	
38	GIN4+	G port (+)LVDS CH4 differential data input	
39	HIN0-	H port (-)LVDS CH0 differential data input	
40	HIN0+	H port (+)LVDS CH0 differential data input	
41	HIN1-	H port (-)LVDS CH1 differential data input	
42	HIN1+	H port (+)LVDS CH1 differential data input	
43	HIN2-	H port (-)LVDS CH2 differential data input	

44	HIN2+	H port (+)LVDS CH2 differential data input	
45	HCK-	H port LVDS Clock signal(-)	
46	HCK+	H port LVDS Clock signal(+)	
47	HIN3-	H port (-)LVDS CH3 differential data input	
48	HIN3+	H port (+)LVDS CH3 differential data input	
49	HIN4-	H port (-)LVDS CH4 differential data input	
50	HIN4+	H port (+)LVDS CH4 differential data input	
51	GND		

CN2

Pin No.	Symbol	Function	Remark
1	GND		
2	AIN0-	A port (-)LVDS CH0 differential data input	
3	AIN0+	A port (+)LVDS CH0 differential data input	
4	AIN1-	A port (-)LVDS CH1 differential data input	
5	AIN1+	A port (+)LVDS CH1 differential data input	
6	AIN2-	A port (-)LVDS CH2 differential data input	
7	AIN2+	A port (+)LVDS CH2 differential data input	
8	ACK-	A port LVDS Clock signal(-)	
9	ACK+	A port LVDS Clock signal(+)	
10	AIN3-	A port (-)LVDS CH3 differential data input	
11	AIN3+	A port (+)LVDS CH3 differential data input	
12	AIN4-	A port (-)LVDS CH4 differential data input	
13	AIN4+	A port (+)LVDS CH4 differential data input	
14	BIN0-	B port (-)LVDS CH0 differential data input	
15	BIN0+	B port (+)LVDS CH0 differential data input	
16	BIN1-	B port (-)LVDS CH1 differential data input	
17	BIN1+	B port (+)LVDS CH1 differential data input	
18	BIN2-	B port (-)LVDS CH2 differential data input	
19	BIN2+	B port (+)LVDS CH2 differential data input	
20	BCK-	B port LVDS Clock signal(-)	
21	BCK+	B port LVDS Clock signal(+)	
22	BIN3-	B port (-)LVDS CH3 differential data input	
23	BIN3+	B port (+)LVDS CH3 differential data input	
24	BIN4-	B port (-)LVDS CH4 differential data input	
25	BIN4+	B port (+)LVDS CH4 differential data input	
26	GND		
27	CIN0-	C port (-)LVDS CH0 differential data input	
28	CIN0+	C port (+)LVDS CH0 differential data input	
29	CIN1-	C port (-)LVDS CH1 differential data input	
30	CIN1+	C port (+)LVDS CH1 differential data input	
31	CIN2-	C port (-)LVDS CH2 differential data input	
32	CIN2+	C port (+)LVDS CH2 differential data input	
33	CCK-	C port LVDS Clock signal(-)	
34	CCK+	C port LVDS Clock signal(+)	
35	CIN3-	C port (-)LVDS CH3 differential data input	
36	CIN3+	C port (+)LVDS CH3 differential data input	
37	CIN4-	C port (-)LVDS CH4 differential data input	
38	CIN4+	C port (+)LVDS CH4 differential data input	
39	DIN0-	D port (-)LVDS CH0 differential data input	
40	DIN0+	D port (+)LVDS CH0 differential data input	
41	DIN1-	D port (-)LVDS CH1 differential data input	

42	DIN1+	D port (+)LVDS CH1 differential data input	
43	DIN2-	D port (-)LVDS CH2 differential data input	
44	DIN2+	D port (+)LVDS CH2 differential data input	
45	DCK-	D port LVDS Clock signal(-)	
46	DCK+	D port LVDS Clock signal(+)	
47	DIN3-	D port (-)LVDS CH3 differential data input	
48	DIN3+	D port (+)LVDS CH3 differential data input	
49	DIN4-	D port (-)LVDS CH4 differential data input	
50	DIN4+	D port (+)LVDS CH4 differential data input	
51	GND		

CN3 (Interface signals)

Using connector : SM15B-GHS-TBT(LF)(SN) (J.S.T. Mfg. co.,Ltd)

Mating connector: GHR-15V-S (J.S.T. Mfg. co.,Ltd)

Pin No.	Symbol	Function	Remark
1	Reserved	It is required to set non-connection (OPEN)	
2	Reserved	It is required to set non-connection (OPEN)	
3	Reserved	It is required to set non-connection (OPEN)	
4	Reserved	It is required to set non-connection (OPEN)	
5	FRAME	Frame frequency setting H:60Hz, L:50Hz	Pull up 3.3V(by 2.0kΩ) [Note 1]
6	O/S_SET	O/S operation setting H: O/S driving ON, L: O/S driving OFF	Pull up 3.3V(by 2.0kΩ) [Note 1]
7	SELLVDS	Select LVDS data order [Note 2]	Pull up 3.3V(by 2.0kΩ) [Note 1]
8	Reserved	It is required to set non-connection (OPEN)	
9	Reserved	It is required to set non-connection (OPEN)	
10	Reserved	It is required to set non-connection (OPEN)	
11	Reserved	It is required to set non-connection (OPEN)	
12	Reserved	It is required to set non-connection (OPEN)	
13	Reserved	It is required to set non-connection (OPEN)	
14	Reserved	It is required to set non-connection (OPEN)	
15	GND		

* L: Low level voltage (GND). H: High level voltage (3.3V)

*Connect the GND of the liquid crystal panel drive part to the chassis of the module.

[Note1] The equivalent circuit figure of the terminal

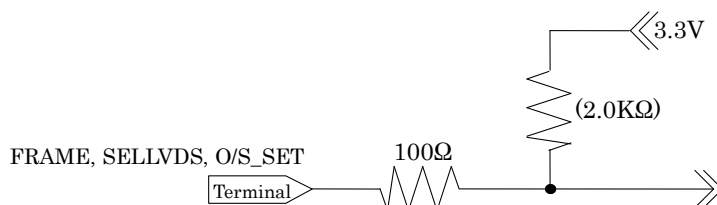

[Note2] LVDS data order (SELLVDS=H:JEIDA Mode, L:VESA Mode)

Transmitter Data	SELLVDS = "L"(GND) LVDS data	SELLVDS = "H"(3.3V) or Open LVDS data
TA0	R0(LSB)	R4
TA1	R1	R5
TA2	R2	R6
TA3	R3	R7
TA4	R4	R8
TA5	R5	R9(MSB)
TA6	G0(LSB)	G4
TB0	G1	G5
TB1	G2	G6
TB2	G3	G7
TB3	G4	G8
TB4	G5	G9(MSB)
TB5	B0(LSB)	B4
TB6	B1	B5
TC0	B2	B6
TC1	B3	B7
TC2	B4	B8
TC3	B5	B9(MSB)
TC4	HSYNC	HSYNC
TC5	VSYNC	VSYNC
TC6	DE	DE
TD0	R6	R2
TD1	R7	R3
TD2	G6	G2
TD3	G7	G3
TD4	B6	B2
TD5	B7	B3
TD6	N/A	N/A
TE0	R8	R0(LSB)
TE1	R9(MSB)	R1
TE2	G8	G0(LSB)
TE3	G9(MSB)	G1
TE4	B8	B0(LSB)
TE5	B9(MSB)	B1
TE6	N/A	N/A

NA: Not Available

*Since the display position is prescribed by the rise of DE (Display Enable) signal,
Please do not fix DE signal during operation at "High".

*HSYNC and VSYNC are not necessary

• LVDS data order (SELLVDS = "L")

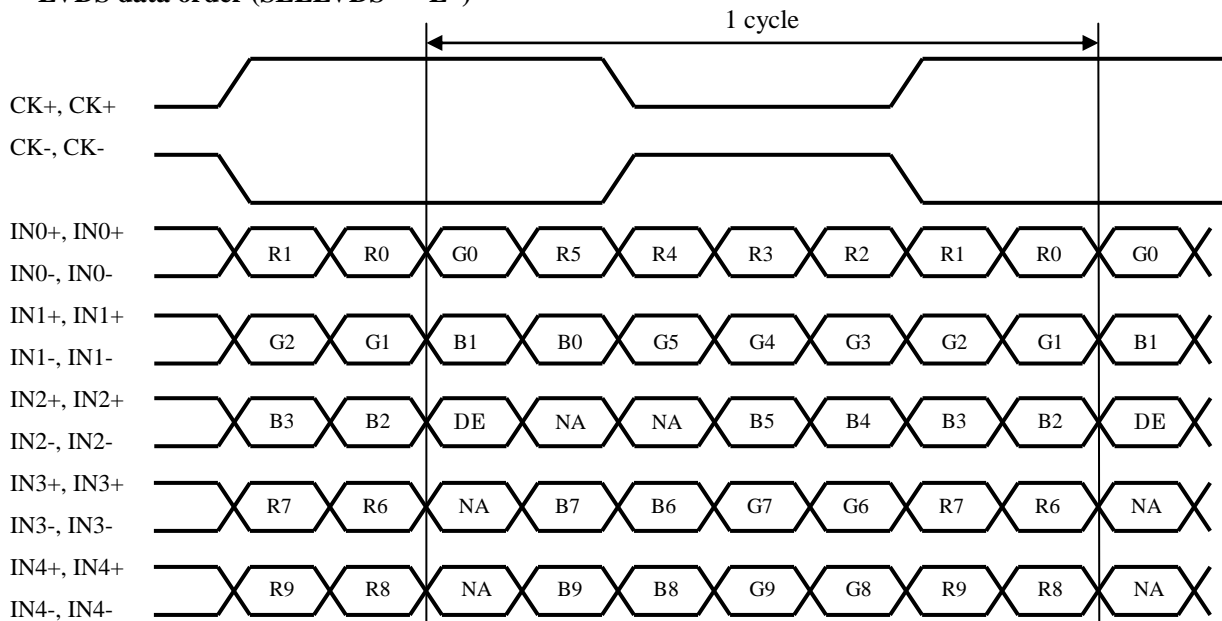

• LVDS data order (SELLVDS = "H")

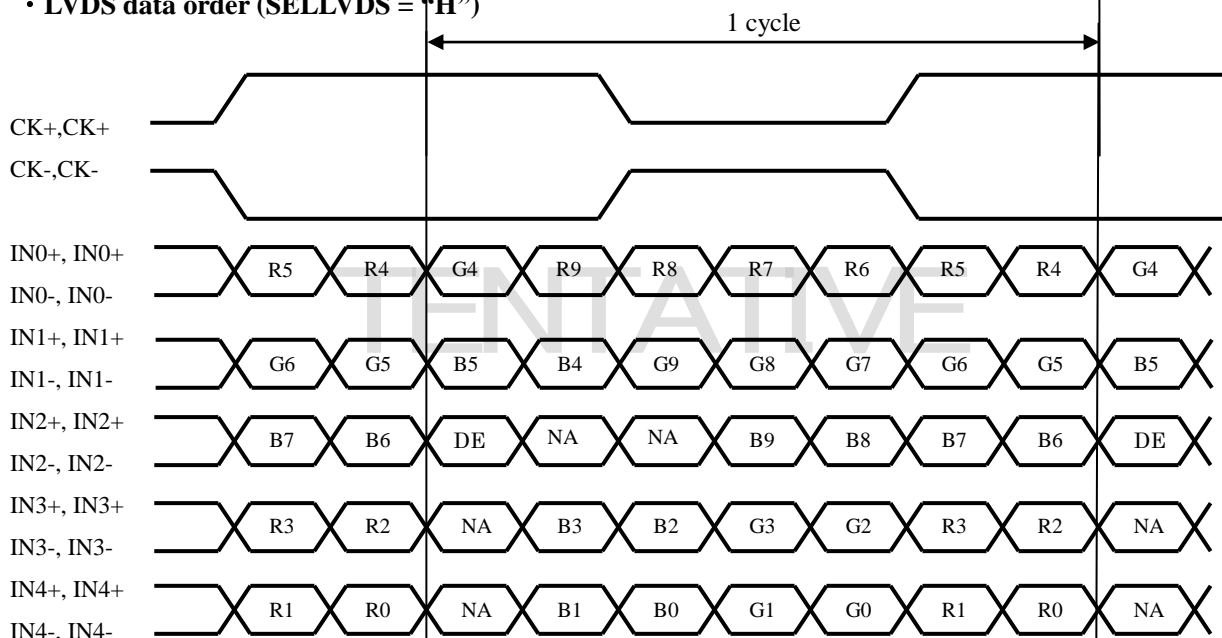

DE: Display Enable, NA: Not Available (Fixed Low)

CN4 (+12V DC power supply) on CONTROL PWB

Using connector: SM05B-PASS (J.S.T. Mfg. Co.,Ltd)

Mating connector: PAP-05V-S (J.S.T. Mfg. Co.,Ltd)

Pin No.	Symbol	Function	Remark
1	VCC	+12V Power Supply	
2	VCC	+12V Power Supply	
3	VCC	+12V Power Supply	
4	GND	GND	
5	GND	GND	

*Current rating : 3A (AWG#22)

Block Diagram (LCD Module)

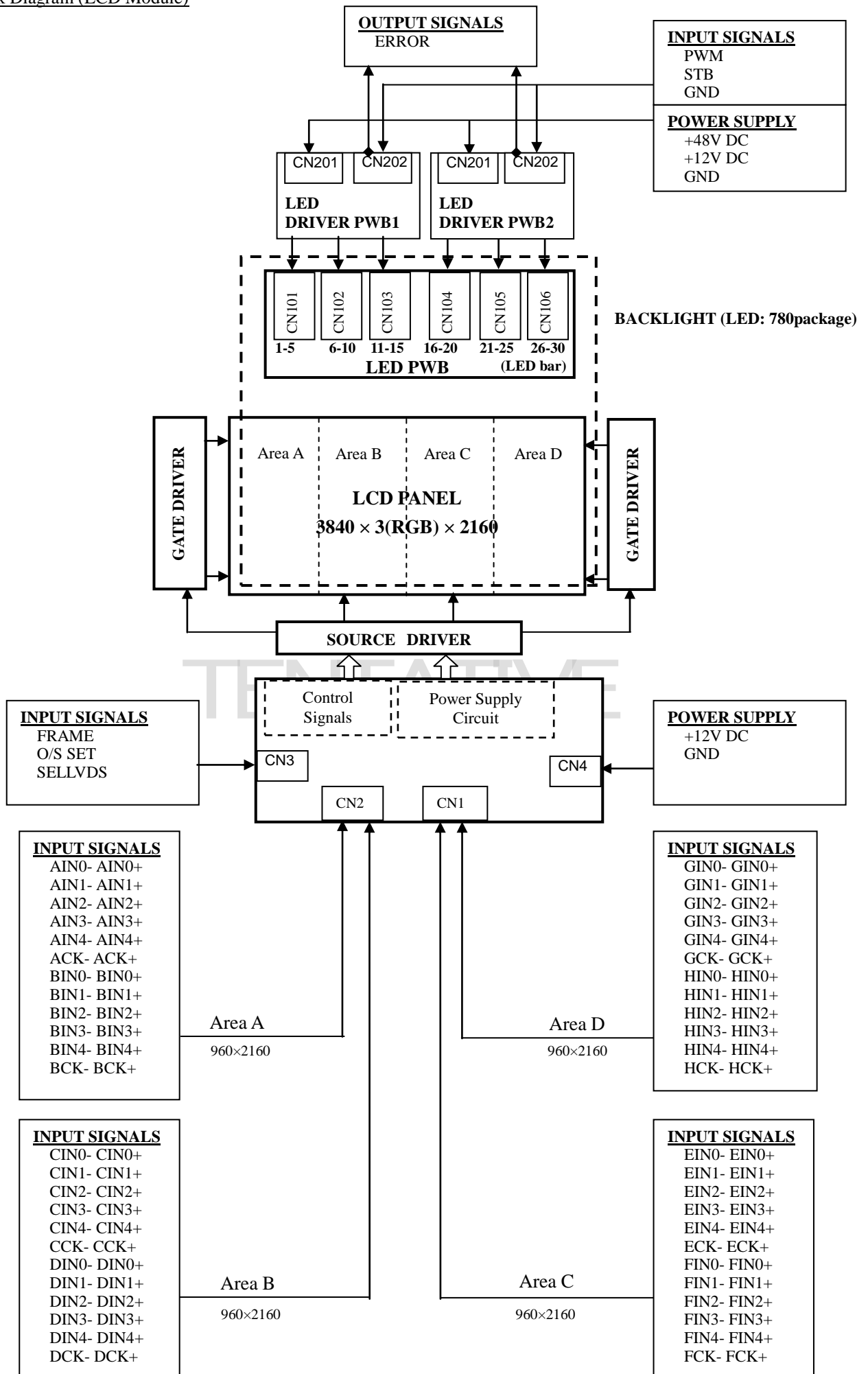

Interface block diagram

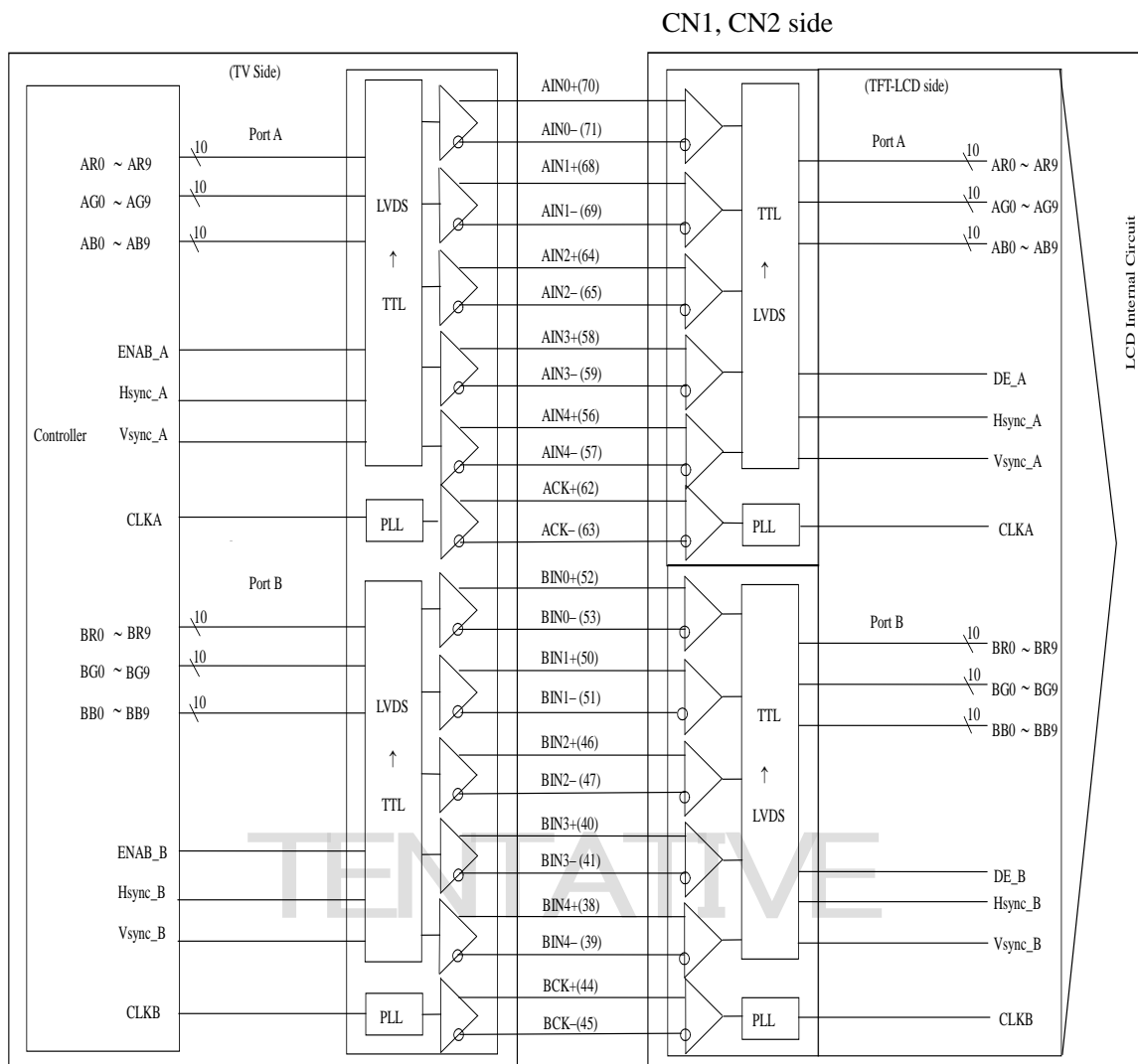

Corresponding Transmitter: THC63LVD1023B (THine) or equivalent device

4-2. Backlight driving (TBD)

CN201 (DC power supply of LED DRIVER PWB1) ※Shown in Fig.1

Using connector: S16B-PASK-2 (J.S.T. Mfg. co.,Ltd)

Matching connector: PAP-16V-S (J.S.T. Mfg. co.,Ltd)

Pin No.	Symbol	Function	Remark
1	VLED1	+48V Power Supply	
2	VLED1	+48V Power Supply	
3	VLED1	+48V Power Supply	
4	VLED1	+48V Power Supply	
5	VLED1	+48V Power Supply	
6	VLED1	+48V Power Supply	
7	VLED1	+48V Power Supply	
8	GND		
9	VLED2	+12V Power Supply	
10	GND		
11	GND		
12	GND		
13	GND		
14	GND		
15	GND		
16	GND		

*Current rating : 3A (AWG#22)

CN202 (Control signal of LED DRIVER PWB1)

Using connector: S09B-PASK-2 (J.S.T. Mfg. co.,Ltd)

Matching connector: PAP-09V-S (J.S.T. Mfg. co.,Ltd)

Pin No.	Symbol	Function	Remark
1	Reserved	It is required to set non-connection (OPEN)	
2	Reserved	It is required to set non-connection (OPEN)	
3	GND		
4	Reserved	It is required to set non-connection (OPEN)	
5	Reserved	It is required to set non-connection (OPEN)	
6	ERROR	ERROR signal output Error: Low output	(Pull up) 【Note 1】
7	PWM	PWM dimming frequency	Pull up (Duty:100%) 【Note 2】
8	STB	LED backlight operation setting H: ON, L: OFF	Pull up (Backlight:ON) 【Note 2】
9	Reserved	It is required to set non-connection (OPEN)	

【Note 1】 ERROR: Open, Short, over current, over voltage, over heat

CN201 (DC power supply of LED DRIVER PWB2) ※Shown in Fig.1

Using connector: S16B-PASK-2 (J.S.T. Mfg. co.,Ltd)

Matching connector: PAP-16V-S (J.S.T. Mfg. co.,Ltd)

Pin No.	Symbol	Function	Remark
1	VLED1	+48V Power Supply	
2	VLED1	+48V Power Supply	
3	VLED1	+48V Power Supply	
4	VLED1	+48V Power Supply	
5	VLED1	+48V Power Supply	
6	VLED1	+48V Power Supply	
7	VLED1	+48V Power Supply	
8	GND		
9	VLED2	+12V Power Supply	
10	GND		
11	GND		
12	GND		
13	GND		
14	GND		
15	GND		
16	GND		

*Current rating : 3A (AWG#22)

CN202 (Control signal of LED DRIVER PWB2)

Using connector: S09B-PASK-2 (J.S.T. Mfg. co.,Ltd)

Matching connector: PAP-09V-S (J.S.T. Mfg. co.,Ltd)

Pin No.	Symbol	Function	Remark
1	Reserved	It is required to set non-connection (OPEN)	
2	Reserved	It is required to set non-connection (OPEN)	
3	GND		
4	Reserved	It is required to set non-connection (OPEN)	
5	Reserved	It is required to set non-connection (OPEN)	
6	ERROR	ERROR signal output * Error: Low output	(Pull up) 【Note 1】
7	PWM	PWM dimming frequency	Pull up (Duty:100%) 【Note 2】
8	STB	LED backlight operation setting H: ON, L: OFF	Pull up (Backlight:ON) 【Note 2】
9	Reserved	It is required to set non-connection (OPEN)	

*ERROR: Open, Short, over current, over voltage, over heat

【Note 1】 ERROR: Open, Short, over current, over voltage, over heat

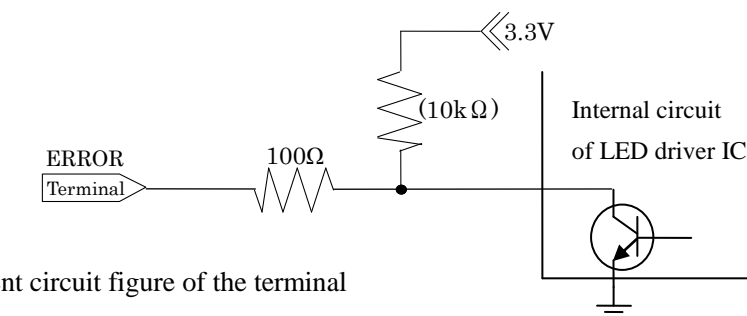

【Note 2】 The equivalent circuit figure of the terminal

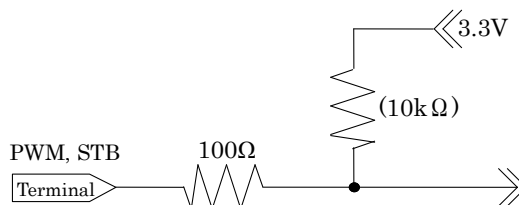

4-3. Backlight electrical characteristic

LED DRIVER PWB

Parameter	Symbol	Min.	Typ.	Max.	Unit	Remark
Supply voltage	V_{LED1}	45.6	48	50.4	V	PWM duty=100%
	V_{LED2}	11.4	12	12.6	V	
Current dissipation	I_{LED1}	TBD	(3.5)	TBD	A	
	I_{LED2}	TBD	(70)	(200)	mA	
Inrush current	I_{RUSH1}	-	-	(20)	A	V_{LED1}
PWM dimming frequency	f_{PWM}	-	-	(480)	Hz	
PWM dimming on duty	D_{PWM}	(5)	-	100	%	
Input Low voltage	V_{IL}	0	-	(0.7)	V	
Input High voltage	V_{IH}	(2.7)	-	3.3	V	

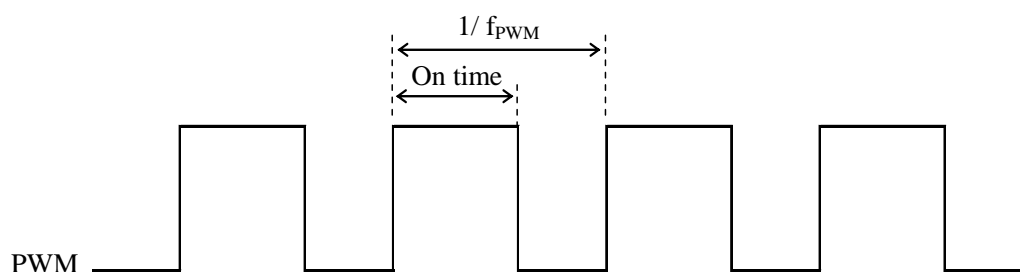

5. Absolute Maximum Ratings

Parameter	Symbol	Ratings	Unit	Remark
Input voltage	V_I	-0.3 ~ 3.6	V	[Note 1]
12V supply voltage (for Control)	VCC	0 ~ +14	V	
Supply voltage (for LED driver)	V_{LED1}	0 ~ +63	V	
	V_{LED2}	0 ~ +14	V	
Storage temperature	T_{stg}	-25 ~ +60	°C	[Note 2] [Note 3]
Operation temperature (Ambient)	T_a	0 ~ +(40)	°C	

[Note 1] FRAME, SELLVDS, O/S_SET

[Note 2] Humidity 95%RH Max. ($T_a \leq 40^\circ\text{C}$)

Maximum wet-bulb temperature at 39°C or less. ($T_a > 40^\circ\text{C}$) / No condensation.

[Note 3] Glass surface temperature: (55) °C Max.

6. Electrical Characteristics

6-1. Control circuit driving

Parameter	Symbol	Min.	Typ.	Max.	Unit	Remark	
+12V supply voltage	Supply voltage	V _{CC}	11.4	12.0	12.6	V	[Note1]
	Current dissipation	I _{CC}	-	(1.5)	(3.0)	A	[Note2]
	Inrush current	I _{RUSH1}	-	TBD	-	A	t ₁ =500us [Note5]
		I _{RUSH2}	-	TBD	-	A	t ₁ >5ms [Note5]
Permissible input ripple voltage	V _{RP}	-	-	100	mV _{P-P}	V _{CC} = +12.0V	
Input Low voltage	V _{IL}	0	-	1.0	V	[Note4]	
Input High voltage	V _{IH}	2.3	-	3.3	V		
Input leak current (Low)	I _{IL}	-	-	400	μA	V _I = 0V	
Input leak current (High)	I _{IH}	-	-	100	μA	V _I = 3.3V	
Terminal resistor	R _T	-	100	-	Ω	Differential input	
Input Differential Voltage	V _{ID}	200	400	600	mV	[Note3]	
Differential Input common mode voltage	V _{CM}	V _{ID} /2	1.2	2.4- V _{ID} /2	V	[Note3]	

[Note]V_{CM}: Common mode voltage of LVDS driver.

[Note 1]

Input voltage sequences

$$0.1 \text{ ms} < t_1 \leq 20 \text{ ms} \quad 10\text{ms} < t_6 \leq 1\text{s}$$

$$10 \text{ ms} < t_2 \leq 50 \text{ ms} \quad 0 < t_7 \leq 50 \text{ ms}$$

$$2.5 \text{ s} < t_3$$

$$10\text{ms} < t_4 \quad 10\text{ms} < t_9$$

$$(20\text{ms}) \leq t_5 \quad 1 \text{ s} \leq t_{10}$$

Dip conditions for supply voltage

$$\text{a) } 6.5\text{V} \leq V_{CC} < 10.8\text{V}$$

$$t_d \leq 10 \text{ ms}$$

$$\text{b) } V_{CC} < 6.5 \text{ V}$$

Dip conditions for supply voltage is based on input voltage sequence.

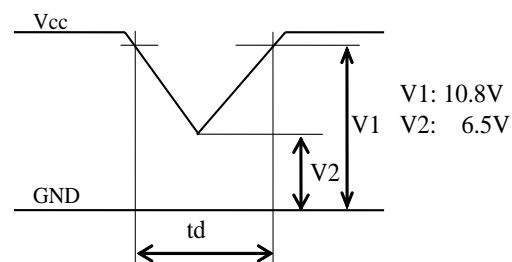
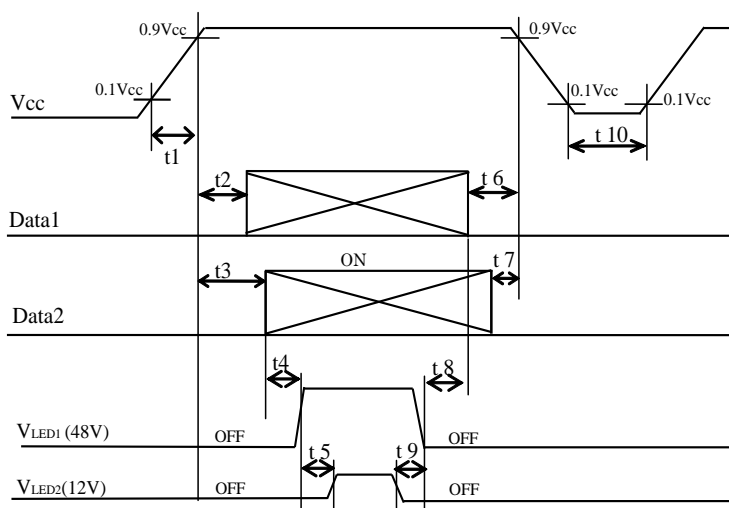

Data1: ACK±, BCK±, BCK±, DCK±, ECK±, FCK±, GCK±, HCK±,

AIN0±, AIN1±, AIN2±, AIN3±, AIN4±, BIN0±, BIN1±, BIN2±, BIN3±, BIN4±,

CIN0±, CIN1±, CIN2±, CIN3±, CIN4±, DIN0±, DIN1±, DIN2±, DIN3±, DIN4±,

EIN0±, EIN1±, EIN2±, EIN3±, EIN4±, FIN0±, FIN1±, FIN2±, FIN3±, FIN4±,

GIN0±, GIN1±, GIN2±, GIN3±, GIN4±, HIN0±, HIN1±, HIN2±, HIN3±, HIN4±

Data2: SELLVDS, FRAME, O/S_SET

* About the relation between data input and back light lighting, please base on the above-mentioned input sequence. When back light is switched on before panel operation or after a panel operation stop, it may not display normally. But this phenomenon is not based on change of an incoming signal, and does not give damage to a liquid crystal display.

[Note 2] Typical current situation: 1024 gray-bar patterns. (Vcc = +12.0V)

The explanation of RGB gray scale is seen in section 8.

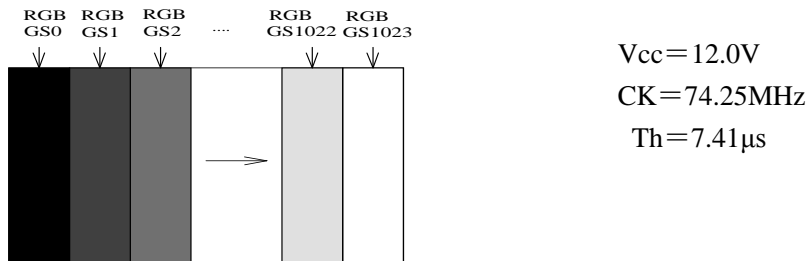

Max current situation: 2H checker board design pattern

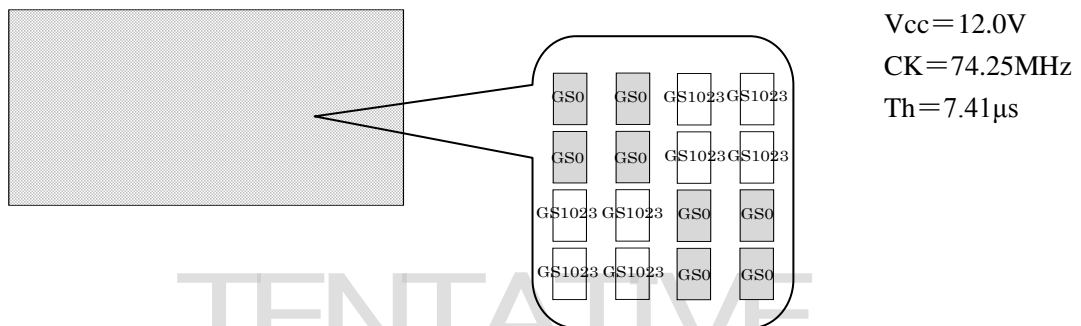

[Note3] ACK±, BCK±, BCK±, DCK±, ECK±, FCK±, GCK±, HCK±,
AIN0±, AIN1±, AIN2±, AIN3±, BIN0±, BIN1±, BIN2±, BIN3±,
CIN0±, CIN1±, CIN2±, CIN3±, DIN0±, DIN1±, DIN2±, DIN3±,
EIN0±, EIN1±, EIN2±, EIN3±, FIN0±, FIN1±, FIN2±, FIN3±,
GIN0±, GIN1±, GIN2±, GIN3±, HIN0±, HIN1±, HIN2±, HIN3±

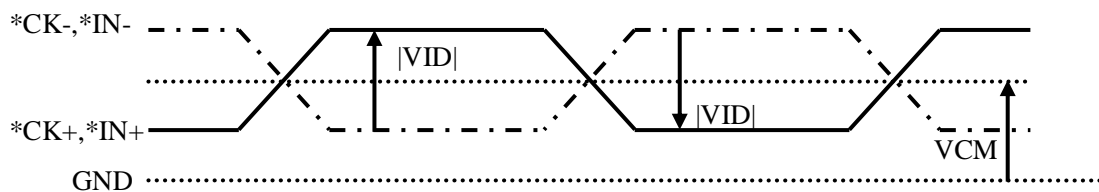

[Note4] SELLVDS, FRAME, O/S_SET

[Note5] Vcc12V inrush current waveform

TBD

7. Timing characteristics of input signals

7-1. Timing characteristics

Timing diagrams of input signal are shown in Fig.2.

Parameter	Symbol	Min.	Typ.	Max.	Unit	Remark
Clock	Frequency	1/Tc	(69)	74.25	(76)	MHz
Data enable signal	Horizontal period	TH	(542)	550	(600)	clock
			7.3	7.41	8.05	μs
	Horizontal period (High)	THd	480	480	480	clock
	Vertical period	TV	(2218)	2250	TBD	line
		(47)	60	(63)	Hz	
Vertical period (High)	TVd	2160	2160	2160	line	

[Note] *When vertical period is very long, flicker and others may occur.

*Please turn off the module after it shows the black screen.

*Please make sure that length of vertical period should become of an integral multiple of the horizontal length of period. Otherwise, the screen may not display properly.

*As for your final setting of driving timing, we will conduct operation check test at our side, Please inform your final setting.

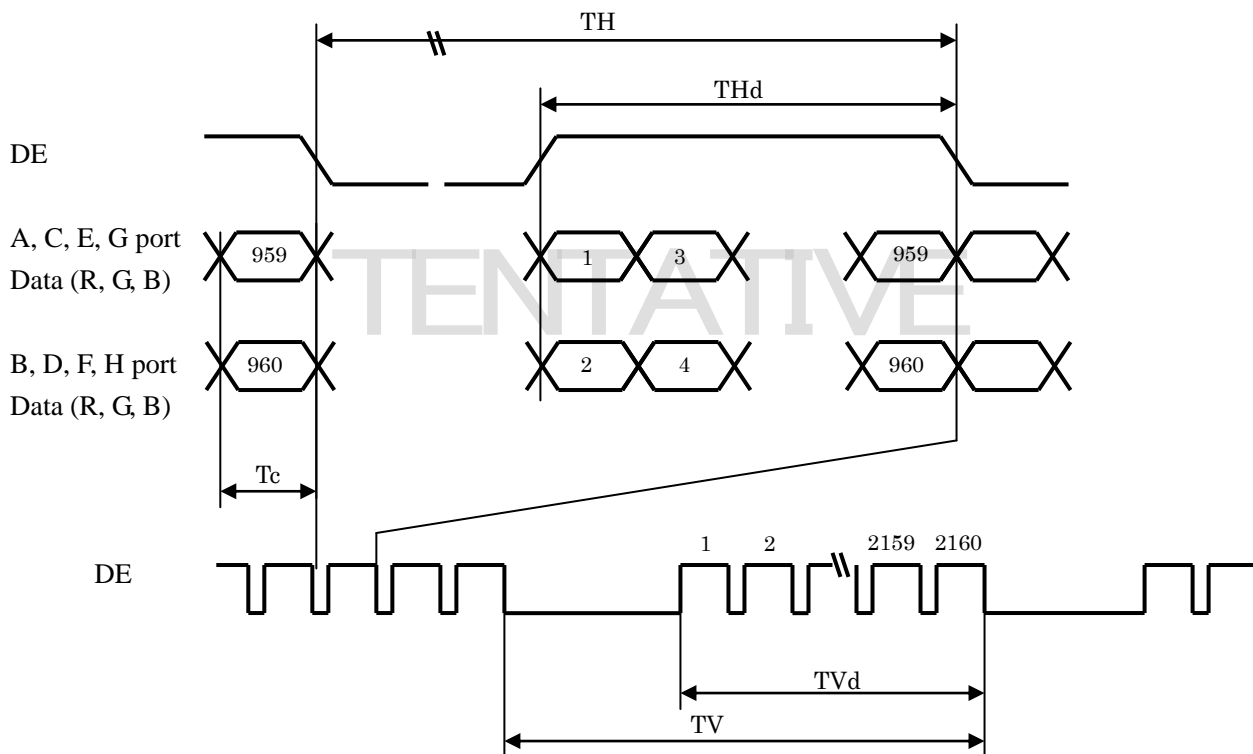
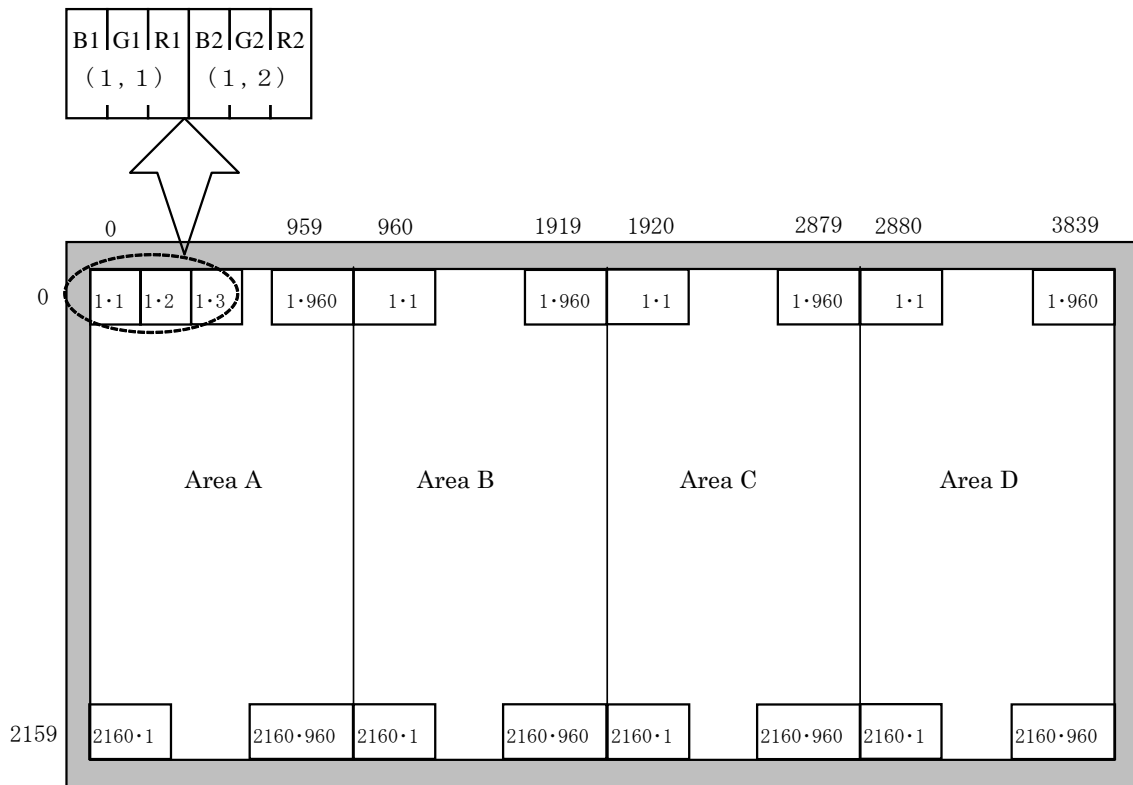

Fig.2 Timing characteristics of input signals

Please make the clock and the synchronization signal input to each area less than plus or minus 1CLK for reference clock (CLK_A) of area A.

7-2. Input data signal and display position on the screen



Display position of Dat (V,H)

TENTATIVE

8. Input Signal, Basic Display Colors and Gray Scale of Each Color

	Colors & Gray scale	Data signal																											
		Gray Scale	R0 R1 R2 R3 R4 R5 R6 R7 R8 R9	G0 G1 G2 G3 G4 G5 G6 G7 G8 G9	B0 B1 B2 B3 B4 B5 B6 B7 B8 B9																								
Basic Color	Black	–	0 0 0 0 0 0 0 0 0 0	0 0 0 0 0 0 0 0 0 0	0 0 0 0 0 0 0 0 0 0																								
	Blue	–	0 0 0 0 0 0 0 0 0 0	0 0 0 0 0 0 0 0 0 0	1 1 1 1 1 1 1 1 1 1																								
	Green	–	0 0 0 0 0 0 0 0 0 0	1 1 1 1 1 1 1 1 1 1	0 0 0 0 0 0 0 0 0 0																								
	Cyan	–	0 0 0 0 0 0 0 0 0 0	1 1 1 1 1 1 1 1 1 1	1 1 1 1 1 1 1 1 1 1																								
	Red	–	1 1 1 1 1 1 1 1 1 1	0 0 0 0 0 0 0 0 0 0	0 0 0 0 0 0 0 0 0 0																								
	Magenta	–	1 1 1 1 1 1 1 1 1 1	0 0 0 0 0 0 0 0 0 0	1 1 1 1 1 1 1 1 1 1																								
	Yellow	–	1 1 1 1 1 1 1 1 1 1	1 1 1 1 1 1 1 1 1 1	0 0 0 0 0 0 0 0 0 0																								
	White	–	1 1 1 1 1 1 1 1 1 1	1 1 1 1 1 1 1 1 1 1	1 1 1 1 1 1 1 1 1 1																								
Gray Scale of Red	Black	GS0	0 0 0 0 0 0 0 0 0 0	0 0 0 0 0 0 0 0 0 0	0 0 0 0 0 0 0 0 0 0																								
	↑	GS1	1 0 0 0 0 0 0 0 0 0	0 0 0 0 0 0 0 0 0 0	0 0 0 0 0 0 0 0 0 0																								
	Darker	GS2	0 1 0 0 0 0 0 0 0 0	0 0 0 0 0 0 0 0 0 0	0 0 0 0 0 0 0 0 0 0																								
	↑	↓																											
	↓	↓																											
	Brighter	GS1021	1 0 1 1 1 1 1 1 1 1	0 0 0 0 0 0 0 0 0 0	0 0 0 0 0 0 0 0 0 0																								
	↓	GS1022	0 1 1 1 1 1 1 1 1 1	0 0 0 0 0 0 0 0 0 0	0 0 0 0 0 0 0 0 0 0																								
	Red	GS1023	1 1 1 1 1 1 1 1 1 1	0 0 0 0 0 0 0 0 0 0	0 0 0 0 0 0 0 0 0 0																								
Gray Scale of Green	Black	GS0	0 0 0 0 0 0 0 0 0 0	0 0 0 0 0 0 0 0 0 0	0 0 0 0 0 0 0 0 0 0																								
	↑	GS1	0 0 0 0 0 0 0 0 0 0	1 0 0 0 0 0 0 0 0 0	0 0 0 0 0 0 0 0 0 0																								
	Darker	GS2	0 0 0 0 0 0 0 0 0 0	0 1 0 0 0 0 0 0 0 0	0 0 0 0 0 0 0 0 0 0																								
	↑	↓																											
	↓	↓																											
	Brighter	GS1021	0 0 0 0 0 0 0 0 0 0	1 0 1 1 1 1 1 1 1 1	0 0 0 0 0 0 0 0 0 0																								
	↓	GS1022	0 0 0 0 0 0 0 0 0 0	0 1 1 1 1 1 1 0 0 1	0 0 0 0 0 0 0 0 0 0																								
	Green	GS1023	0 0 0 0 0 0 0 0 0 0	1 1 1 1 1 1 1 1 1 1	0 0 0 0 0 0 0 0 0 0																								
Gray Scale of Blue	Black	GS0	0 0 0 0 0 0 0 0 0 0	0 0 0 0 0 0 0 0 0 0	0 0 0 0 0 0 0 0 0 0																								
	↑	GS1	0 0 0 0 0 0 0 0 0 0	0 0 0 0 0 0 0 0 0 0	1 0 0 0 0 0 0 0 0 0																								
	Darker	GS2	0 0 0 0 0 0 0 0 0 0	0 0 0 0 0 0 0 0 0 0	0 1 0 0 0 0 0 0 0 0																								
	↑	↓																											
	↓	↓																											
	Brighter	GS1021	0 0 0 0 0 0 0 0 0 0	0 0 0 0 0 0 0 0 0 0	1 0 1 1 1 1 1 1 1 1																								
	↓	GS1022	0 0 0 0 0 0 0 0 0 0	0 0 0 0 0 0 0 0 0 0	0 1 1 1 1 1 1 1 1 1																								
	Blue	GS1023	0 0 0 0 0 0 0 0 0 0	0 0 0 0 0 0 0 0 0 0	1 1 1 1 1 1 1 1 1 1																								

0: Low level voltage, 1: High level voltage.

Each basic color can be displayed in 1021 gray scales from 8 bit data signals. According to the combination of total 30 bit data signals, the one billion-color display can be achieved on the screen.

9. Optical characteristics

Test conditions: $V_{CC} = 12.0V$, $PWM=100\%$, Timing: 60Hz, $T_a=25^\circ C$

Parameter	Symbol	Condition	Min.	Typ.	Max.	Unit	Remark	
Viewing angle range	Horizontal	θ_{21} θ_{22}	$CR \geq 10$	70	88	-	Deg.	[Note1][Note4]
	Vertical	θ_{11} θ_{12}		70	88	-	Deg.	
Contrast ratio	CRn	$\theta = 0 \text{ deg}$	TBD	(5000)	-		[Note2][Note4]	
Response time	τ_{DRV}		-	(6)	-	ms	[Note3][Note4] [Note5]	
Chromaticity of white	x		(0.253)	(0.283)	(0.313)	-	[Note 4]	
	y		(0.267)	(0.297)	(0.327)	-		
Chromaticity of red	x		(0.610)	(0.640)	(0.670)	-		
	y		(0.300)	(0.330)	(0.360)	-		
Chromaticity of green	x		(0.260)	(0.290)	(0.320)	-		
	y		(0.570)	(0.600)	(0.630)	-		
Chromaticity of blue	x		(0.120)	(0.150)	(0.180)	-		
	y		(0.03)	(0.060)	(0.09)	-		
Luminance of white	Y_{L1}	(350)	(450)	-	cd/m^2	[Note 4]		
Luminance uniformity	δ_w		-	(1.25)		[Note 6]		

Measurement condition: Set the value of duty to maximum luminance of white.

*The measurement shall be executed 120 minutes after lighting at rating.

【Note】 The optical characteristics are measured using the following equipment.

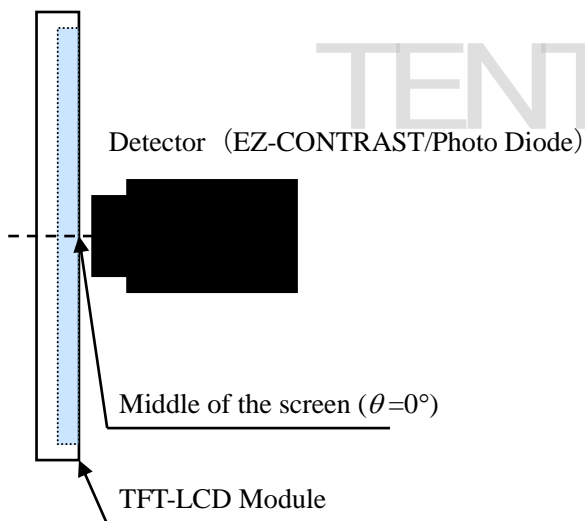

Fig.3-1 Measurement of viewing angle range and response time.

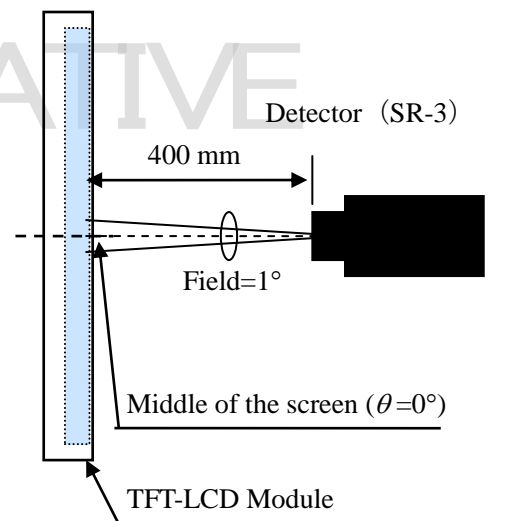
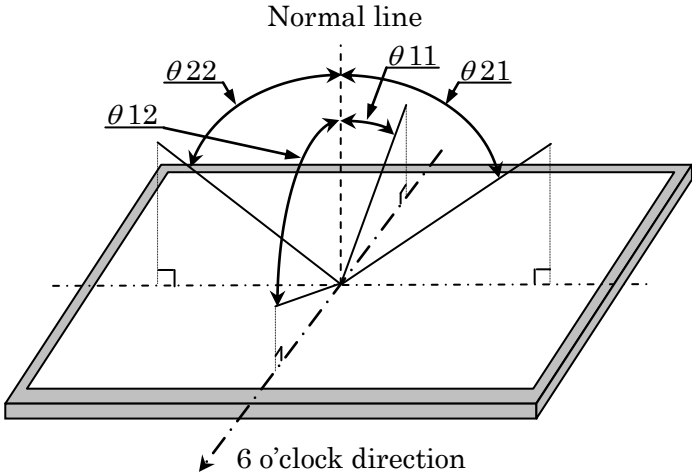

Fig.3-2 Measurement of Contrast, Luminance, Chromaticity.

Viewing angle range: EZ-CONTRAST

Response time : Photo Diode

[Note 1]Definitions of viewing angle range:



[Note 2]Definition of contrast ratio:

The contrast ratio is defined as the following.

$$\text{Contrast Ratio} = \frac{\text{Luminance (brightness) with all pixels white}}{\text{Luminance (brightness) with all pixels black}}$$

[Note 3]Definition of response time

The response time (τ_{Drv}) is defined as the following figure and shall be measured by switching the input signal for “five luminance ratio (0%, 25%, 50%, 75%, and 100%)” and “five luminance ratio (0%, 25%, 50%, 75%, and 100%)”.

	0%	25%	50%	75%	100%
0%		tr: 0%-25%	tr: 0%-50%	tr: 0%-75%	tr: 0%-100%
25%	td: 25%-0%		tr: 25%-50%	tr: 25%-75%	tr: 25%-100%
50%	td: 50%-0%	td: 50%-25%		tr: 50%-75%	tr: 50%-100%
75%	td: 75%-0%	td: 75%-25%	td: 75%-50%		tr: 75%-100%
100%	td: 100%-0%	td: 100%-25%	td: 100%-50%	td: 100%-75%	

t*: x-y...response time from level of gray(x) to level of gray(y)

$$\tau_{\text{Drv}} = \sum (t^*: x-y)/20$$

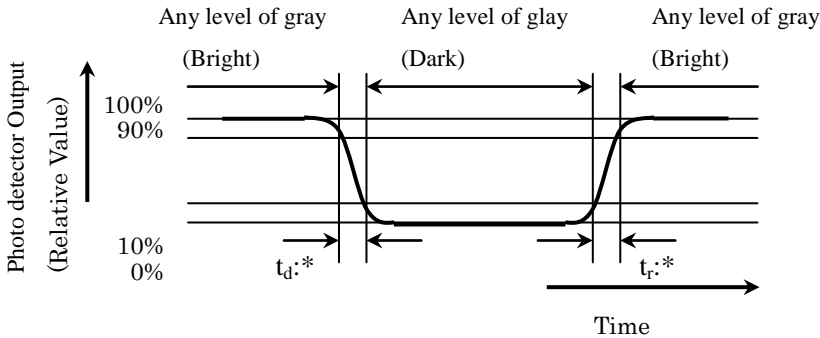

[Note 4]This shall be measured at center of the screen.

[Note 5] Response time is the value when O/S driving is used at typical input time value.

[Note 6] Definition of white uniformity;

White uniformity is defined as the following with five points measurement.

$$\delta W = \frac{\text{Maximum Luminance of five points (Brightness)}}{\text{Minimum Luminance of five points (Brightness)}}$$

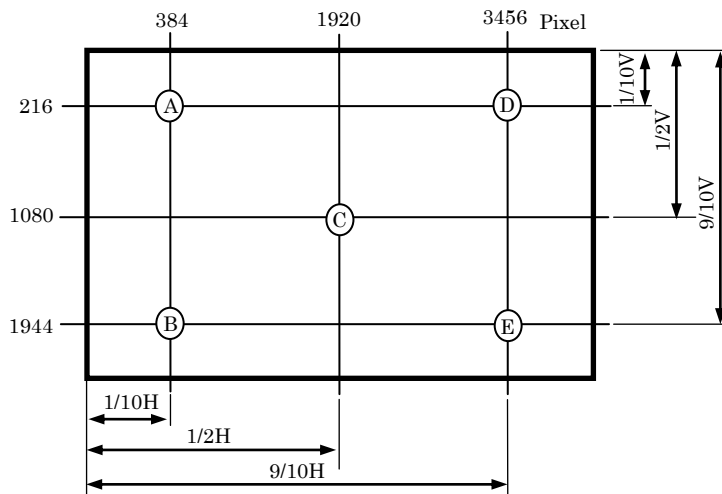

10. Handling Precautions of the module

- Be sure to turn off the power supply when inserting or disconnecting the cable.
- Voltage difference generated by this switching, ΔV_{LED} , may affect a sound output, etc. when the power supply is shared between the LED PWB and its surrounding circuit. So, separate the power supply of the LED PWB with the one of its surrounding circuit.
- Be sure to design the cabinet so that the module can be installed without any extra stress such as warp or twist.
- Since the front polarizer is easily damaged, pay attention not to scratch it.
- Since long contact with water may cause discoloration or spots, wipe off water drop immediately.
- When the panel surface is soiled, wipe it with absorbent cotton or other soft cloth.
- Since the panel is made of glass, it may break or crack if dropped or bumped on hard surface. Handle with care.
- Since CMOS LSI is used in this module, take care of static electricity and take the human earth into consideration when handling.
- The module has some printed circuit boards (PCBs) on the back side, take care to keep them from any stress or pressure when handling or installing the module; otherwise some of electronic parts on the PCBs may be damaged.
- Observe all other precautionary requirements in handling components.
- When some pressure is added onto the module from rear side constantly, it causes display non-uniformity issue, functional defect, etc... So, please avoid such design.
- When giving a touch to the panel at power on supply, it may cause some kinds of degradation. In that case, once turn off the power supply, and turn on after several seconds again, and that is disappear.
- When handling LCD modules and assembling them into cabinets, please be noted that long-term storage in the environment of oxidization or deoxidization gas and the use of such materials as reagent, solvent, adhesive, resin, etc. which generate these gasses, may cause corrosion and discoloration of the LCD modules.

- n) This LCD module is designed to prevent dust from entering into it. However, there would be a possibility to have a bad effect on display performance in case of having dust inside of LCD module. Therefore, please ensure to design your product to keep dust away around LCD module.
- o) Make sure that the LCD module is operated within specified temperature and humidity.
Measures against dust, water, vibration, and heat dissipation structure, etc. are required at the cabinet or equipment side. And image retention may occur if same fixed pattern is displayed for a long time.
In some cases, it may not disappear. It is recommended to use moving picture periodically.
After long-term static display, periodical power-off or screen saver is needed. For screen saver, Moving picture or black pattern is strongly recommended.
Avoid combination of background and image with large different luminance.
Please consider the design and operating environment.
- p) Ultra-violet ray filter is necessary in outdoor environment.
- q) Operation for 24 hours a day is NOT recommended.

11. Packing form

- a) Piling number of cartons: TBD
- b) Packing quantity in one carton: TBD
- c) Carton size: TBD (W) × TBD (D) × TBD (H)
- d) Total mass of one carton filled with full modules: TBD kg
- e) Packing Form is shown in Fig 4. TBD

12. Reliability test item

*only as for the module.

No.	Test item	Condition
1	High temperature storage test	Ta=60°C t=240h
2	Low temperature storage test	Ta=-25°C t=240h
3	High temperature and high humidity operation test	Ta=40°C ; 95%RH t=240h (No condensation)
4	High temperature operation test	Ta=40°C t=240h
5	Low temperature operation test	Ta= 0°C t=240h
6	Vibration test* (non-operation)	Frequency: 10~57Hz/Vibration width (one side): 0.075mm : 58~500Hz/Acceleration: 9.8 m/s ² Sweep time: 11 minutes Test period: 3 hours (1h for each direction of X, Y, Z)
7	Shock test* (non-operation)	Maximum acceleration: 294m/s ² Pulse width: 11ms, sinusoidal half wave Direction: +/-X, once for each direction.
8	ESD	At the following conditions, it is a thing without incorrect operation and destruction. (1)Non-operation: Contact electric discharge +/-10kV Non-contact electric discharge +/-20kV (2)Operation Contact electric discharge +/-8kV Non-contact electric discharge +/-15kV Conditions: 150Pf, 330ohm

【Note】 these items apply to the single module.

【Result evaluation criteria】

Under the display quality test condition with the normal operation state, there shall be no change, which may affect a practical display function.

13. Others

1) Lot No. Label

The label that displays SHARP, product model (LK601R3LA1x), a product number is stuck on the back of the module.



How to express Lot No.

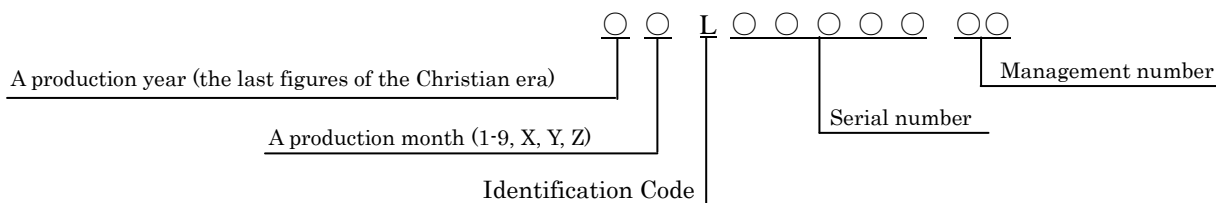

2) Packing Label

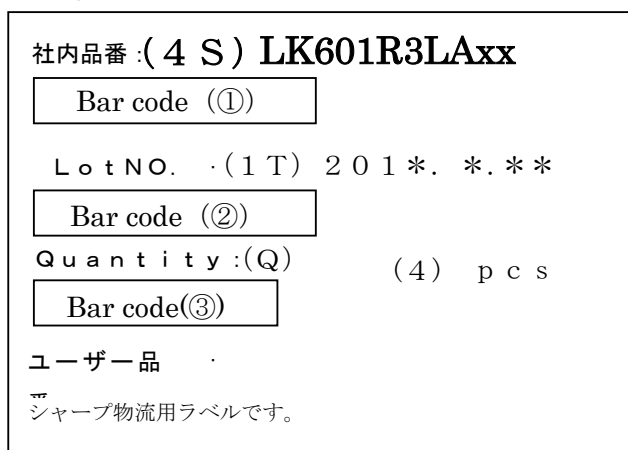

- ① Management No.
- ② Lot No. (Date)
- ③ Quantity

3) Adjusting volume has been set optimally before shipment, so do not change any adjusted value.

If adjusted value is changed, the specification may not be satisfied.

4) Disassembling the module can cause permanent damage and should be strictly avoided.

5) Please be careful since image retention may occur when a fixed pattern is displayed for a long time.

6) The chemical compound, which causes the destruction of ozone layer, is not being used.

7) When any question or issue occurs, it shall be solved by mutual discussion.

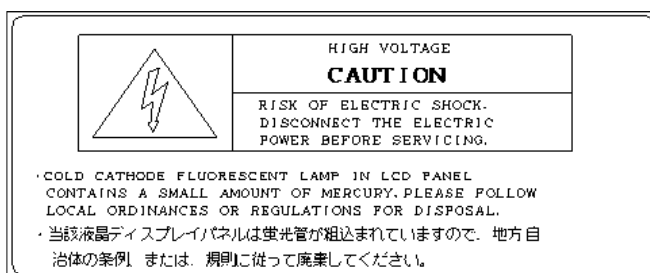

8) This LCD is appropriate to UL. Below figure shows the UL label.

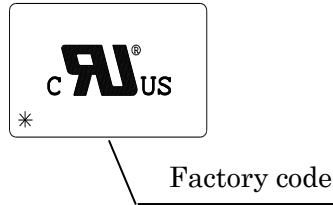

9) This module is corresponded to RoHS

10) The chemical compound, which causes the destruction of ozone layer, is not being used.

11) Rust on the module is not taken up a problem.

12) Appearance quality and standard are referred to the outgoing incoming inspections.

14. Carton storage condition

Temperature	0°C to 40°C
Humidity	95%RH or less
Reference condition	: 20°C to 35°C, 85%RH or less (summer) : 5°C to 15°C, 85%RH or less (winter) • the total storage time (40°C,95%RH) : 240h or less
Sunlight	Be sure to shelter a product from the direct sunlight.
Atmosphere	Harmful gas, such as acid and alkali which bites electronic components and/or wires must not be detected.
Notes	Be sure to put cartons on palette or base, don't put it on floor, and store them with removing from wall Please take care of ventilation in storehouse and around cartons, and control changing temperature is within limits of natural environment
Storage life	1 year

