

PREPARED BY: <i>Kazuya Toyota</i>	SHARP	SPEC No. LA1-06049A
APPROVED BY: <i>Hideoaki Yamuchi</i>		FILE No.
		ISSUED: Aug.23.2006
		PAGE : 20pages
	MOBILE LIQUID CRYSTAL DISPLAY GROUP SHARP CORPORATION SPECIFICATION	APPLICABLE GROUP MOBILE LIQUID CRYSTAL DISPLAY GROUP.1

DEVICE SPECIFICATION FOR

TFT-LCD module

 MODEL No. LQ038Q3DC01

CUSTOMER'S APPROVAL

DATE _____

BY _____

PRESENTED

BY *Hiroshi Hamada* _____

H. HAMADA
 Department General manager
 Engineering Department. 1
 Mobile LCD Design Center
 Mobile Liquid Crystal Display Group. 1
 SHARP CORPORATION

NOTICE

This publication is the proprietary of SHARP and is copyrighted, with all rights reserved. Under the copyright laws, no part of this publication may be reproduced or transmitted in any form or by any means, electronic or mechanical for any purpose, in whole or in part, without the express written permission of SHARP. Express written permission is also required before any use of this publication may be made by a third party.

The application circuit examples in this publication are provided to explain the representative applications of SHARP's devices and are not intended to guarantee any circuit design or permit any industrial property right or other rights to be executed. SHARP takes no responsibility for any problems related to any industrial property right or a third party resulting from the use of SHARP's devices, except for those resulting directly from device manufacturing processes.

In the absence of confirmation by device specification sheets, SHARP takes no responsibility for any defects that occur in equipment using any of SHARP's devices, shown in catalogs, data books, etc. Contact SHARP in order to obtain the latest device specification sheets before using any SHARP's device.

SHARP reserves the right to make changes in the specifications, characteristics, data, materials, structures and other contents described herein at any time without notice in order to improve design or reliability. Contact SHARP in order to obtain the latest specification sheets before using any SHARP's device. Manufacturing locations are also subject to change without notice.

Observe the following points when using any device in this publication. SHARP takes no responsibility for damage caused by improper use of the devices.

The devices in this publication are designed for general electronic equipment use.

The appropriate design measures should be taken to ensure reliability and safety when SHARP's devices are used for equipment such as:

- Transportation control and safety equipment(i.e.,aircraft, trains, automobiles, etc.)
- Traffic signals • Gas leakage sensor breakers • Alarm equipment • Various safety devices etc.

SHARP's devices shall not be used for equipment that requires extremely high level of reliability, such as:

- Military and space applications • Nuclear power control equipment
- Medical equipment for life support

Contact a SHARP representative, in advance, when intending to use SHARP's devices for any "specific" applications other than those recommended by SHARP.

Contact and consult with a SHARP representative if there are any questions about the contents of this publication.

1 Applicable TFT-LCD module

This specification applies to the color TFT-LCD module, LQ038Q3DC01.

2 Overview

This module is a color active matrix transmissive LCD module incorporating amorphous silicon TFT (Thin Film Transistor).

It is composed of a color TFT-LCD panel, driver ICs, control circuits and a backlight unit.

Graphics and texts can be displayed on a 320×RGB×240 dots panel with 262,144 colors by suitable control supplying from the outside.

The LED-driving circuit is not built in this module.

- a) Fine images with stripe aligned 76,800 pixels on 3.8 inch diagonal screen
- b) Adapting a wide viewing angle technology [best viewing angle: 6 o'clock direction]
- c) High contrast, thanks to active matrix drive system
- d) Natural coloring reproducibility by employing normally-white-mode, which has good nature in coloring
- e) Image inversion both horizontally and vertically
- f) This module is adapted to RoHS compliance.

3 Mechanical Specifications

items	specifications	unit
Display size (Diagonal)	9.6 (3.8")	cm
Active display area	76.80 (H) × 57.60 (V)	mm
Pixel format	320(H) × RGB × 240(V)	dot
	(1 pixel=R+G+B dots)	-
Pixel pitch	0.240(H) x 0.240(V)	mm
Pixel configuration	R,G,B vertical stripe	-
LCD mode	Normally white/Twisted Nematic	-
Dimension *	90.6 (W) × 79.9 (H) × 9.9(D)	mm
Mass	105 (max)	g
Surface treatment	Clear hard coat(3H)	

* Fig.1 shows dimensions of the module.

4 Input Signal Assignment

4.1 TFT-LCD Panel driving section

Used connector : IMSA-9637S-40Y922 (IRISO Electronics co.,ltd.)

Table 4-1 Functional table of CN1 terminals

Pin No.	Symbol	Function	Polarity
1	Hsync	Horizontal Sync signal	Positive
2	Vsync	Vertical Sync signal	Positive
3	GND	GND	
4	CK	Clock signal for sampling each datum	
5	GND	GND	
6	R0	RED Data signal (LSB)	
7	R1	RED Data signal	
8	R2	RED Data signal	
9	R3	RED Data signal	
10	R4	RED Data signal	
11	R5	RED Data signal (MSB)	
12	GND	GND	
13	G0	GREEN data signal (LSB)	
14	G1	GREEN data signal	
15	G2	GREEN data signal	
16	G3	GREEN data signal	
17	G4	GREEN data signal	
18	G5	GREEN data signal (MSB)	
19	GND	GND	
20	B0	BLUE data signal (LSB)	
21	B1	BLUE data signal	
22	B2	BLUE data signal	
23	B3	BLUE data signal	
24	B4	BLUE data signal	
25	B5	BLUE data signal (MSB)	
26	GND	GND	
27	VREV	Vertical scanning direction control signal (built in pull-up resistor)	[Note 1]
28	HREV	Horizontal Scanning direction control signal (built in pull-up resistor)	[Note 1]
29	GND	GND	
30	ENAB	Data Enable signal(built in pull-down resistor) (Control signal for image location in horizontal direction)	[Note 2]
31	Vcc	Power supply in	
32	Vcc	Power supply in	
33	Vcc	Power supply in	
34	NC		
35	-LED1	LED1 cathode terminal	
36	NC		
37	+LED1	LED1 anode terminal	
38	+LED2	LED2 anode terminal	
39	NC		
40	-LED2	LED2 cathode terminal	

[Note 1]

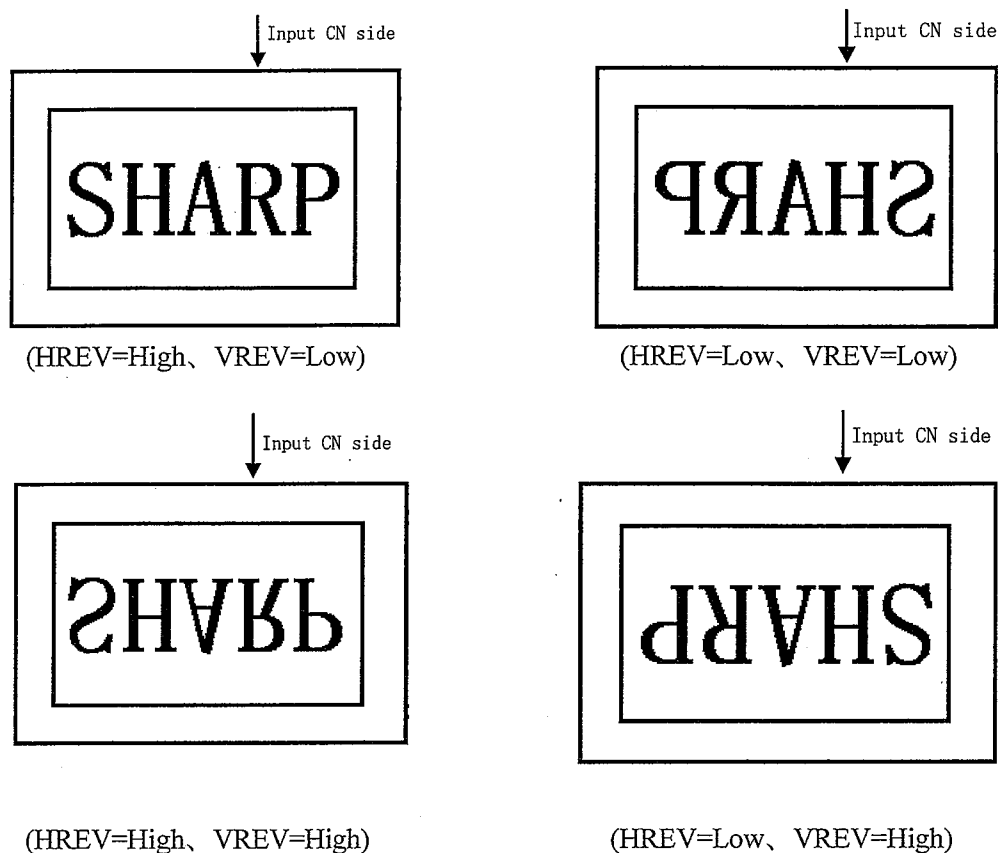

[Note 2]

The horizontal display location is designated and controlled by rising timing of ENAB signal. However if ENAB signal is fixed to "Low", display location is designated by the default setting in the module.(Don't use the module by fixing ENAB to "High")

5 Absolute Maximum Ratings

Parameter	Symbol	MIN	MAX	Unit	Remark
Input voltage	V_I	-0.3	$V_{CC}+0.3$	V	$T_a=25^{\circ}\text{C}$ [Note 1]
Supply voltage	V_{CC}	0	+5.5	V	$T_a=25^{\circ}\text{C}$
Storage temperature	T_{stg}	-30	+80	$^{\circ}\text{C}$	[Note 2,3,4]
Operating temperature (ambient temperature)	T_{opa}	-30	+65	$^{\circ}\text{C}$	[Note 2,3,4,6,7]
Operating temperature (Panel surface)	T_{opp}	-30	+70	$^{\circ}\text{C}$	[Note 2,3,5,6,7]
Forward current ($T_a=25^{\circ}\text{C}$)	I_f	0	35	mA	

[Note 1] CK, R0 ~ R5, G0 ~ G5, B0 ~ B5, Hsync, Vsync, ENAB, HREV and VREV

[Note 2] Humidity: Less than 95%RH at $T_a \leq 40^{\circ}\text{C}$ and Maximum wet-bulb temperature must not exceed 39°C at $T_a > 40^{\circ}\text{C}$, with no condensation.

[Note 3] The operating temperature only guarantees operation of the circuit. For contrast, speed response, and other factors related to display quality, judgment is done using the ambient temperature $T_a = +25^{\circ}\text{C}$.

[Note 4] This rating applies to all parts of the module and should not be exceeded.

[Note 5] This rating applies to all parts of the panel and should not be exceeded.

[Note 6] $I_f=8.0\text{mA}$ MAX.

[Note 7] Both ambient temperature and panel surface temperature must not exceed the maximum temperature.

6 Electrical characteristics

Table 6-1 TFT-LCD Panel driving section

Ta=25°C

Parameter	Symbol	Min	Typ	Max	Unit	Remarks
Supply voltage	Vcc	+3.0	+3.3	+3.6	V	[Note1]
Current dissipation	Icc	-	130	195	mA	[Note2]Vcc=3.3V
Allowed input ripple voltage	VRF	-	-	100	mV p-p	Vcc=3.3V
Input voltage ("Low" state)	VIL	-	-	0.3Vcc	V	[Note3]
Input voltage ("High" state)	VIH	0.7Vcc	-	-	V	
Input leakage current (low)	IIL1	-	-	1.0	μA	VI=0V[Note4]
	IIL2	-	-	1.0	μA	VI=0V[Note5]
	IIL3	2.0	-	75.0	μA	VI=0V[Note6]
Input leakage current (High)	IIL1	-	-	1.0	μA	VI=Vcc[Note4]
	IOH2	2.0	-	75	μA	VI=Vcc[Note5]
	IOH3	-	-	1.0	μA	VI=Vcc[Note6]

[Note1] Vcc turn-on/off conditions

- 0 < t1 ≤ 10ms
- 0 < t2 ≤ 10ms
- 0 < t3 ≤ 1s
- 1s ≤ t4

Vcc-dip conditions

- 1) At 2.8V ≤ Vcc < 3.0V
td ≤ 10ms
- 2) At Vcc < 2.8V
Vcc dip conditions should also follow the Vcc turn-on/off conditions

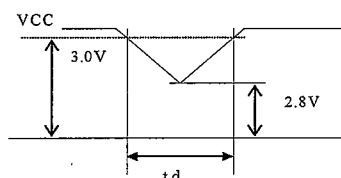
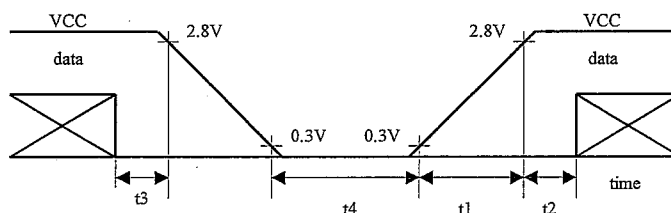

[Note2] Current dissipation (Typ.):

When Monochrome 64 level-gray-bar pattern is displayed

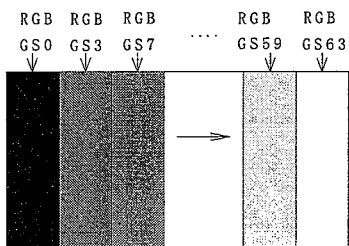

Current dissipation (Max.):

When GS42 and GS21 gray bar are displayed alternately.

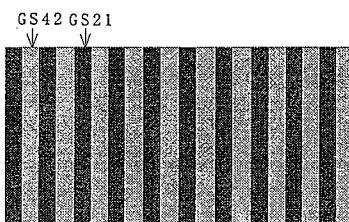

[Note3] CK, R0~R5, G0~G5, B0~B5, Hsync, Vsync, ENAB, HREV and VREV

[Note4] CK,R0~R5, G0~G5, B0~B5, Hsync, and Vsync

[Note5] ENAB

[Note6] HREV and VREV

6.1 Backlight driving Section

The Backlight uses 14 LED(7pcs × 2systems).

•The backlight circuit

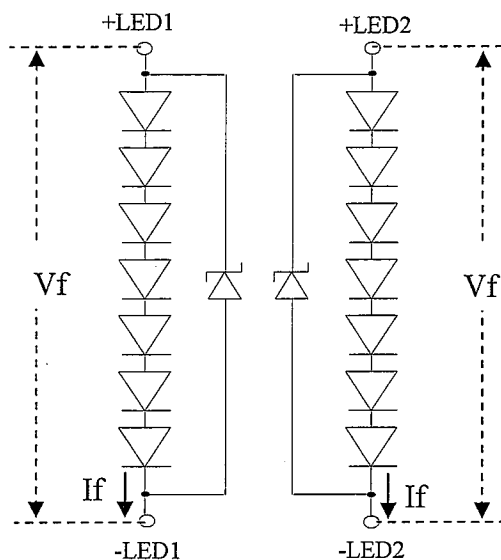

Table 6-2 backlight ratings

Parameter	Symbol	Min.	Typ.	Max.	Unit	Remarks
LED voltage	Vf +70	14.7	18.5	20	V	Ta=+70°C [Note6-7]
	Vf +25	16.5	20	22	V	Ta=+25°C [Note6-8]
	Vf -30	18.0	22	24.5	V	Ta=-30°C [Note6-9]
Foward current	If	3.0	7.5	8.0	mA	
electrical requirements	Wf	-	300	-	mW	[Note6-10]

[Note6-7] If=7.5mA, for each line at thermal equilibrium state.

[Note6-8] Ta=+70°C, If=7.5mA, for each line at power supply ON

[Note6-9] Ta=-30°C, If=7.5mA, for each line at power supply ON

[Note6-10] Reference value by calculation $Wf = Vf \times If \times 2$ systems.

7 Timing Characteristics of Input Signals

Timing diagrams of input signal are shown in Fig.3-A,3-B.

7.1 Timing Characteristics

Parameter		Symbol	Min.	Typ.	Max.	Unit	Remark
Clock	Frequency	1/Tc	3.9	6.3	8	MHz	
	“High” time	Tch	50	-	-	ns	
	“Low” time	Tcl	50	-	-	ns	
Data	Setup time	Tds	50	-	-	ns	
	Hold time	Tdh	50	-	-	ns	
Phase difference between Hsync and clock		THc	50	-	120	ns	
Phase difference between Hsync and Vsync		TVh	0	-	TH-10	μs	

7.2 Display Position in horizontal direction

1)ENAB = “Active”

Display position in horizontal direction is designated by rising timing of ENAB signal.(Fig 3-A)

Parameter		Symbol	MIN	TYP	MAX	Unit	Remark
Hsync	Period	TH	55	63.5	80	μs	
			Th+308	400	440	clock	
	Pulse width	THp	4	-	96	clock	
ENAB signal	Setup time	Tes	50	-	Tc-10	ns	
	Pulse width	Tep		320		clock	
Phase difference between Hsync and ENAB signal		THE	14	-	71	clock	
Horizontal display period		THd	320	320	320	clock	

2)ENAB = “Low”(Fig 3-B)

Parameter		Symbol	MIN	TYP	MAX	Unit	Remark
Hsync	Period	TH	55	63.5	80	μs	
			380	400	440	clock	
	Pulse width	THp	4	-	96	clock	
Phase difference between Hsync and ENAB signal		THE	72	72	72	clock	
Horizontal display period		THd	320	320	320	clock	

7.3 Display Position in vertical direction

Parameter		Symbol	MIN	TYP	MAX	Unit	Note
Vsync	Period	TV	242	263	330	line	
	Frequency	1/TV	50	60	-	Hz	[Note 7-1]
	Pulse width	TVp	2	2	200	line	
Vertical data start position		TVs	4	4	4	line	
Vertical display period		TVd	240	240	240	line	

[Note 7-1] In case of lower frequency, the deterioration of display quality, flicker etc., occur.
Please use this module in more than 50Hz. (1/TV)

7.4 Input signal and display on the screen

Display position of input data

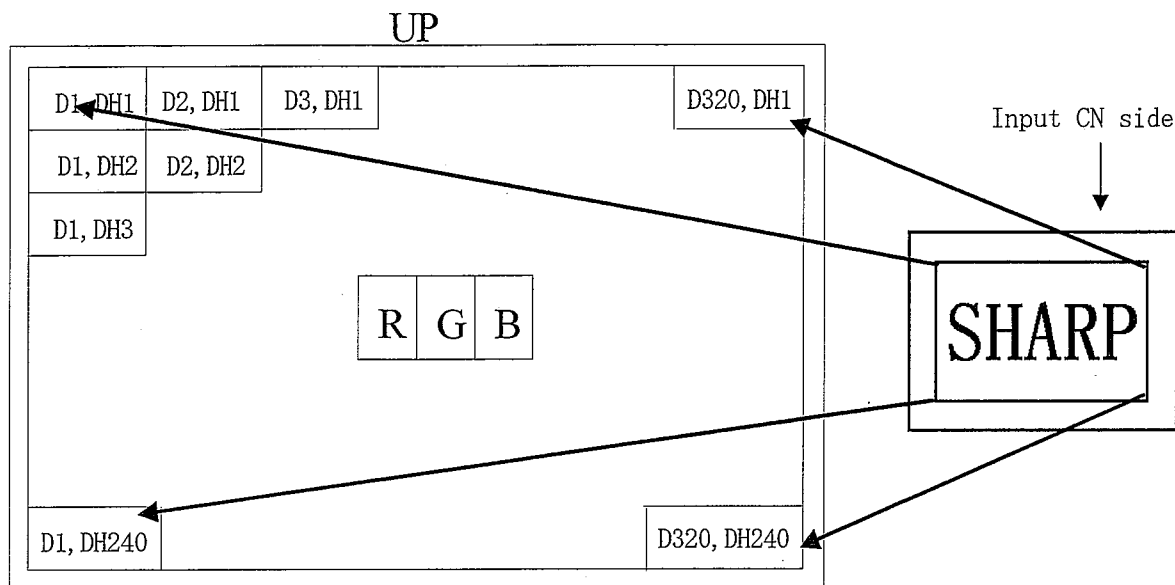

8 Input Signals, Basic Display Colors and Gray Scale of Each Color

	Colors & Gray scale	Data signal																		
		Gray Scale	R0	R1	R2	R3	R4	R5	G0	G1	G2	G3	G4	G5	B0	B1	B2	B3	B4	B5
Basic Color	Black	-	0	0	0	0	0	0	0	0	0	0	0	0	0	0	0	0	0	0
	Blue	-	0	0	0	0	0	0	0	0	0	0	0	0	1	1	1	1	1	1
	Green	-	0	0	0	0	0	0	1	1	1	1	1	1	0	0	0	0	0	0
	Cyan	-	0	0	0	0	0	0	1	1	1	1	1	1	1	1	1	1	1	1
	Red	-	1	1	1	1	1	1	0	0	0	0	0	0	0	0	0	0	0	0
	Magenta	-	1	1	1	1	1	1	0	0	0	0	0	0	1	1	1	1	1	1
	Yellow	-	1	1	1	1	1	1	1	1	1	1	1	1	0	0	0	0	0	0
	White	-	1	1	1	1	1	1	1	1	1	1	1	1	1	1	1	1	1	1
Gray Scale of Red	Black	GS0	0	0	0	0	0	0	0	0	0	0	0	0	0	0	0	0	0	0
	↑	GS1	1	0	0	0	0	0	0	0	0	0	0	0	0	0	0	0	0	0
	Darker	GS2	0	1	0	0	0	0	0	0	0	0	0	0	0	0	0	0	0	0
	↑	↓				↓					↓						↓			
	↓	↓				↓					↓						↓			
	Brighter	GS61	1	0	1	1	1	1	0	0	0	0	0	0	0	0	0	0	0	0
	↓	GS62	0	1	1	1	1	1	0	0	0	0	0	0	0	0	0	0	0	0
Red	GS63	1	1	1	1	1	1	0	0	0	0	0	0	0	0	0	0	0	0	
Gray Scale of Green	Black	GS0	0	0	0	0	0	0	0	0	0	0	0	0	0	0	0	0	0	0
	↑	GS1	0	0	0	0	0	0	1	0	0	0	0	0	0	0	0	0	0	0
	Darker	GS2	0	0	0	0	0	0	0	1	0	0	0	0	0	0	0	0	0	0
	↑	↓				↓					↓						↓			
	↓	↓				↓					↓						↓			
	Brighter	GS61	0	0	0	0	0	0	1	0	1	1	1	1	0	0	0	0	0	0
	↓	GS62	0	0	0	0	0	0	0	1	1	1	1	1	0	0	0	0	0	0
Green	GS63	0	0	0	0	0	0	1	1	1	1	1	1	0	0	0	0	0	0	
Gray Scale of Blue	Black	GS0	0	0	0	0	0	0	0	0	0	0	0	0	0	0	0	0	0	0
	↑	GS1	0	0	0	0	0	0	0	0	0	0	0	0	1	0	0	0	0	0
	Darker	GS2	0	0	0	0	0	0	0	0	0	0	0	0	0	1	0	0	0	0
	↑	↓				↓					↓						↓			
	↓	↓				↓					↓						↓			
	Brighter	GS61	0	0	0	0	0	0	0	0	0	0	0	0	1	0	1	1	1	1
	↓	GS62	0	0	0	0	0	0	0	0	0	0	0	0	0	1	1	1	1	1
Blue	GS63	0	0	0	0	0	0	0	0	0	0	0	0	1	1	1	1	1	1	

0: Low level voltage, 1: High level voltage

Each basic color can be displayed in 64 gray scales from 6 bit data signals. According to the combination of total 18 bit data signals, the 262,144-color display can be achieved on the screen.

9 Optical Specification

Ta=25°C, Vcc=+3.3V

Parameter		Symbol	Condition	Min.	Typ.	Max.	Unit	Remark
Viewing angle Range	Horizontal	$\theta 21, \theta 22$	$CR \geq 5$	60	70	-	° (Deg.)	[Note9-1,4]
	Vertical	$\theta 12$		50	60	-	° (Deg.)	
		$\theta 11$		55	70	-	° (Deg.)	
Contrast ratio		CR max	Best viewing angle	250	450	-	-	[Note9-2,4]
Response time	Rise	Tr	$\theta = 0^\circ$	-	8	20	ms	[Note9-3,4]
	Fall	Td		-	20	40	ms	
Chromaticity of white		x	If=7.5mA	0.263	0.313	0.363	-	[Note9-5]
		y		0.279	0.329	0.379	-	
Luminance		Y		195	240	-	cd/m ²	
LED life time (reference)	+25°C	continuation		-	(40000)	-	hour	[Note9-6]

Following LED driver is used for the lighting evaluation of this backlight unit.

•PQ6CB11X1CP (SHARP CORPORATION)

The optical specifications are measured 30 minute after turning LED on and in a dark room or equivalent condition, according to the method shown in Fig.9-1, 2 below.

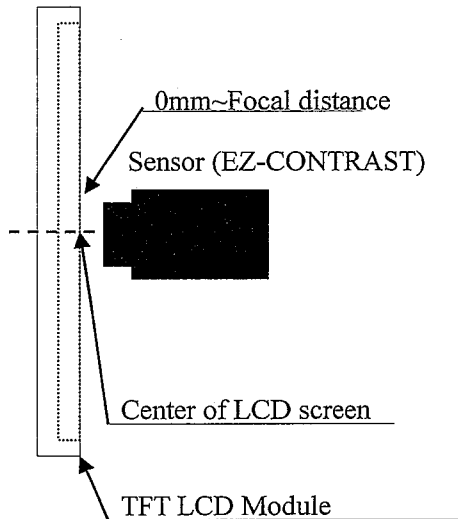

Fig.9-1 Measuring setup for
Viewing angle and Contrast ratio
(BM-5 is used for contrast.)

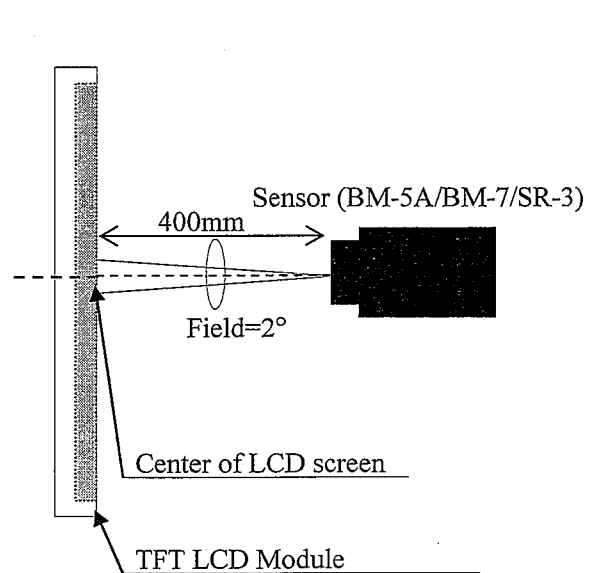
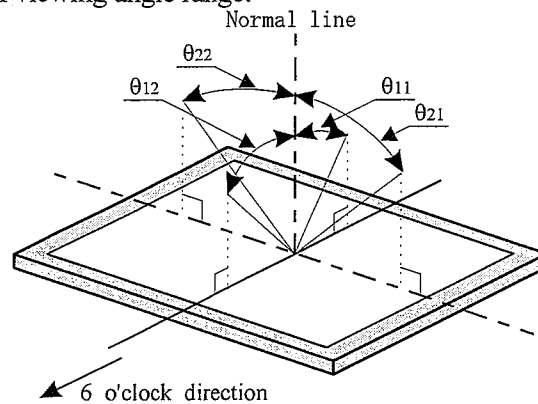

Fig.9-2 Measuring setup for Luminance,
Chromaticity and Response time
(BM-7 is used for Luminance, SR-3 is for response)

[Note9-1] Definitions of viewing angle range:



[Note9-2] Definition of contrast ratio:

The contrast ratio is defined as the following.

$$\text{Contrast Ratio (CR)} = \frac{\text{Luminance (brightness) with all pixels white}}{\text{Luminance (brightness) with all pixels black}}$$

[Note9-3] Definition of response time:

The response time is defined as the following figure and shall be measured by switching the input signal between "black" and "white" alternatively.

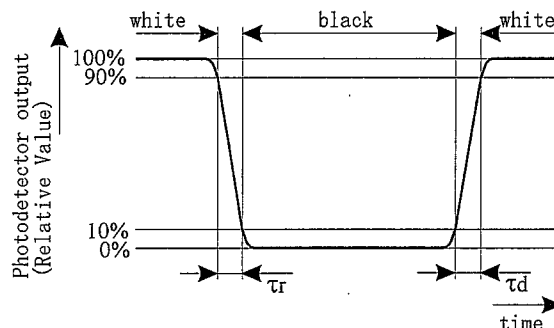

[Note9-4] This parameter should be measured at the center of the screen and 30 minutes after turn-on.

Forward current $I_f = 7.5\text{mA}$

The characteristics are measured when the driver circuit is not powered.

[Note9-5] The best viewing angle of this module is slightly leaned to 6 o'clock from normal line.

In the field where θ_{12} exceeds this angle, gray-scale is reversed partially.

The gray-scale in the field of 12 o'clock direction is brighter than that of 6 o'clock direction and isn't reversed.

[Note9-6] The date for LED is for your reference, because LED is consumable component.

LED life time is defined by below.

(continues on at $T_a = 25^\circ\text{C}$, $I_f = 7.5\text{mA}$)

When a brightness become 50% of the initial value under the standard condition.

10 Display Qualities

Please refer to the Outgoing Inspection Standard.

11 Handling Instruction

11.1 Assembling the module

- 1) The TFT-LCD module is designed to be mounted on equipment using the mounting hole in the four corners of the module at the rear side. On mounting the module, as the nominal diameter 2.6mm tapping screw (fastening torque is 0.35 through 0.40 N·m) is recommended, be sure to fix the module on the same plane, taking care not to wrap or twist the module. The tapping depth of the screw into LCD module must be less than 3.5mm.
The pressing module, (ex. touching switch etc.) causes disordered image. So taking care that such pressure does not affect the LCD module.
- 2) Please power off the module before you connect or disconnect input connector.

11.2 Instruction for assembling

Since the front polarizer is easily damaged, pay attention to avoid rubbing with something hard or sharp. A protective film "Laminator" is attached on the module screen to avoid scratch and/or dust.

You are recommended remove the "Laminator" just before you install the module into your products, paying attention to avoid electrostatic damage as followings.

A) Work Environment

Since removing laminator may causes electrostatic charge that tends to attract dust, the following work environment would be desired.

- a) Floor: Conductive treatment having 1MΩ resistance onto floor's tile
- b) The room free from dust coming from outdoor environment, and put an adhesive mat at entrances.
- c) Humidity from 50% to 70% and temperature from 15°C to 27°C are desirable.
- d) Worker should ware conductive shoes, conductive fatigue, conductive glove and earth wrist band.

B) Instruction for working

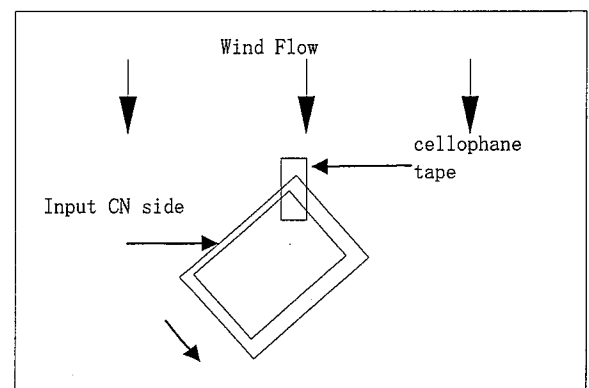
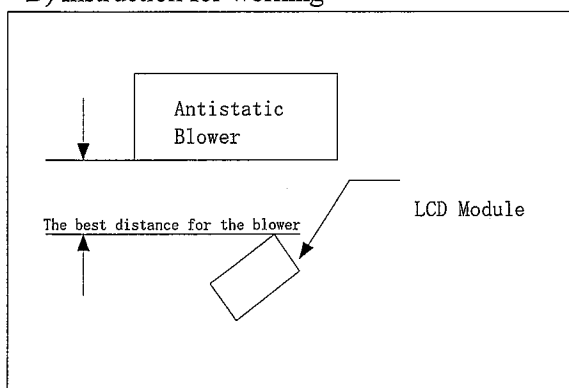

- a) Wind direction of an antistatic blower should slightly downward to properly blow the module. The distance between the blower and the module should be the best distance for the blower. Also, pay attention to the direction of the module.
- b) To prevent polarizer from scratching, adhesive tape (cellophane tape) should be stuck at the part of laminator sheet, which is closed to blower. [See the above]
- c) Pull slowly adhesive tape to peel the laminator off, with spending more than 5 second.

d) The module without laminator should be moved to the next process to prevent adhesion of dust.

e) How to eliminate dust on polarizer.

Blow dust away by N₂ blower having measures of electrostatics

Since the front polarizer is easily damaged, wiping dust off is not adequate.

If the polarizer is soiled, it is suggested to peel dust off by using adhesive surface of adhesive tape.

When the metal section [shield case or shield back case] is soiled, wipe it off with dry and soft cloth. If not so easy, breathe upon it then wipe off. If the water droplet or fat is left for long term, it may cause stain or tarnish, it should be wipe off immediately.

Since TFT-LCD panel is made of glass substrate, dropping the panel or banging it against hard objects may cause cracking or fragmentation.

Since CMOS LSIs are incorporated in this module, please pay special care to electrostatic while handling it, and earth human body.

11.3 Caution in product design

The notes and cautions below should be followed when product is designed with this module.

The module should be protected with cover to prevent salt content and/or water droplet.

Take enough shielding countermeasure not to interfere to peripheral electronic device.

11.4 Others

The LCD has the nature that its performance is degradation by ultra-violet light. Don't leave the LCD module in direct sunlight or strong ultra violet ray.

If stored at the temperatures lower than the rated storage temperature, the LC may freeze and it may cause LCD panel damage. If storage temperature exceeds the specified rating, the molecular orientation of the LC may change to that of a liquid, and they may not revert to their original state. Store the module in normal room temperature.

The inductive loss caused by routing of lamp lead wire, which is closed to conductive section, may require the kick-off voltage greater than specified kick-off voltage.

The liquid crystal may leak out when the LCD is broken. If the liquid crystal drip into the eyes or mouth washes it out immediately.

The caution to other ordinal electronic component should be followed also.

Don't use or store the module in corrosive gas environment.

12 Packing Form

12.1 Fig.4 shows packaging form.

12.2 Carton stock conditions

- a) Maximum number of Carton being stuck: 10
- b) Maximum number of product contained: 50 Unit
- c) Carton size: 534mm (W) x 349mm (D) x 195mm (H)
- d) Total mass (for 50Unit): Approximately 6.9kg
- e) Carton stock environment:
 - 1) Temperature: 0 ~ 40°C
 - 2) Humidity: Up to 60%RH
 - 3) Ambiance: No gases bite into electronic components and wiring materials
 - 4) Period: Approximately 3month
 - 5) Unpacking: To prevent LCD module from damaging by ESD, unpack the module with effective measure after controlling humidity 50%RH or more.

13 Marking of product name

13.1 Serial No. indication

Serial No. is indicated by labeling. The location is given in Fig.1 Outline dimension.

Indicated contents:

LQ038Q3DC01	XXXXXXXXXX
Model name	Serial No.

Serial No. contents	1st digit:	last digit of produced year (ex. 2006 → "6")
	2nd digit:	Produced month 1, 2, 3 ~ 9, X, Y, Z
	3rd ~ 8th digit:	Sequential number 000001 ~
	9th digit:	Internal control code

14 Miscellaneous

- a) Variable resistor has been set optimally before shipment, so do not change any adjusted value. If adjusted value is changed, the specification may not be satisfied.
- b) Don't disassemble this module, it may cause malfunction.
- c) Image retention may occur when the fixed image is display for long time.
- d) Liquid crystal panel drive input FFC/FPC specification
 - The following FFC/FPC is recommended for input connector.
[IMSA-9637S-40Y922 (IRISO Electronics co.,ltd.) , 40pin 0.5mm pitch]
 - The terminal of FFC/FPC of input connector recommend to be gold or gold plated.
Because point of contact of the connection is gold plated.

15 Reliability Test Items

Note: The condition of temperature is the operation temperature given in Absolute maximum rating.

No.	Test parameter	Conditions
1	High temperature storage test	Leaves the module at Ta=+80°C for 240h
2	Low temperature storage test	Leaves the module at Ta=-30°C for 240h
3	High temperature & high humidity operation test	Operates the module at Ta=+40°C; 95%RH for 240h (No condensation)
4	High temperature operation test	Operates the module with +65°C at ambient temperature for 240h
5	Low temperature operation test	Operates the module at Ta=-30°C for 240h
6	Strength against ESD	±200V·200pF [0Ω] one time for each terminal
7	Shock test (non- operating)	Max. acceleration : 980m/s ² Pulse width : 6ms, half sine wave Direction : ±X,±Y,±Z once for each direction.
8	Vibration test (non- operating)	Frequency : 10~57Hz/Vibration width (one side):0.15mm : 58~500Hz/ acceleration:19.6m/s ² Sweep time : 11 minutes Test period : 3 hours (1 hour for each direction of X,Y,Z)
9	Thermal shock test	-30°C ~ +80°C /50 cycle [0.5h] [0.5h]

[Result Evaluation Criteria]

Under the display quality test conditions with normal operation state, these shall be no change which may affect practical display function.

[Note] The directions of X, Y, Z are defined as below:

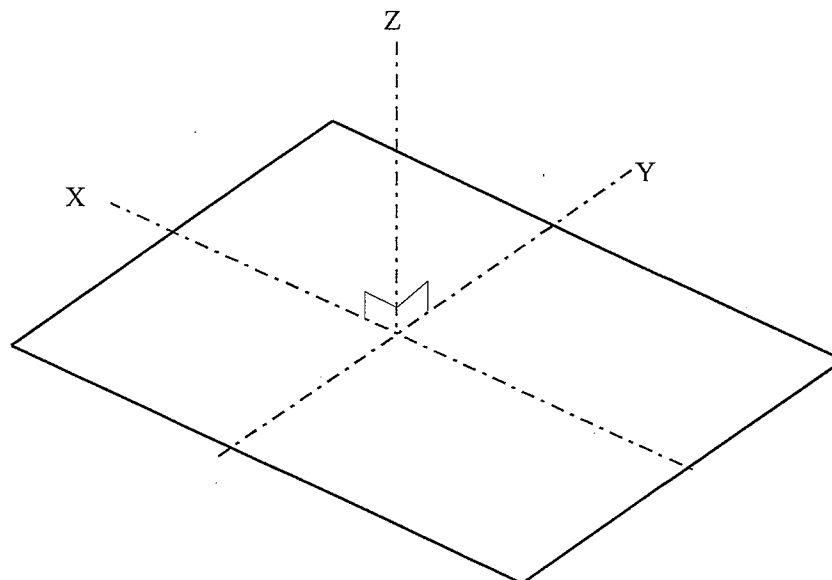

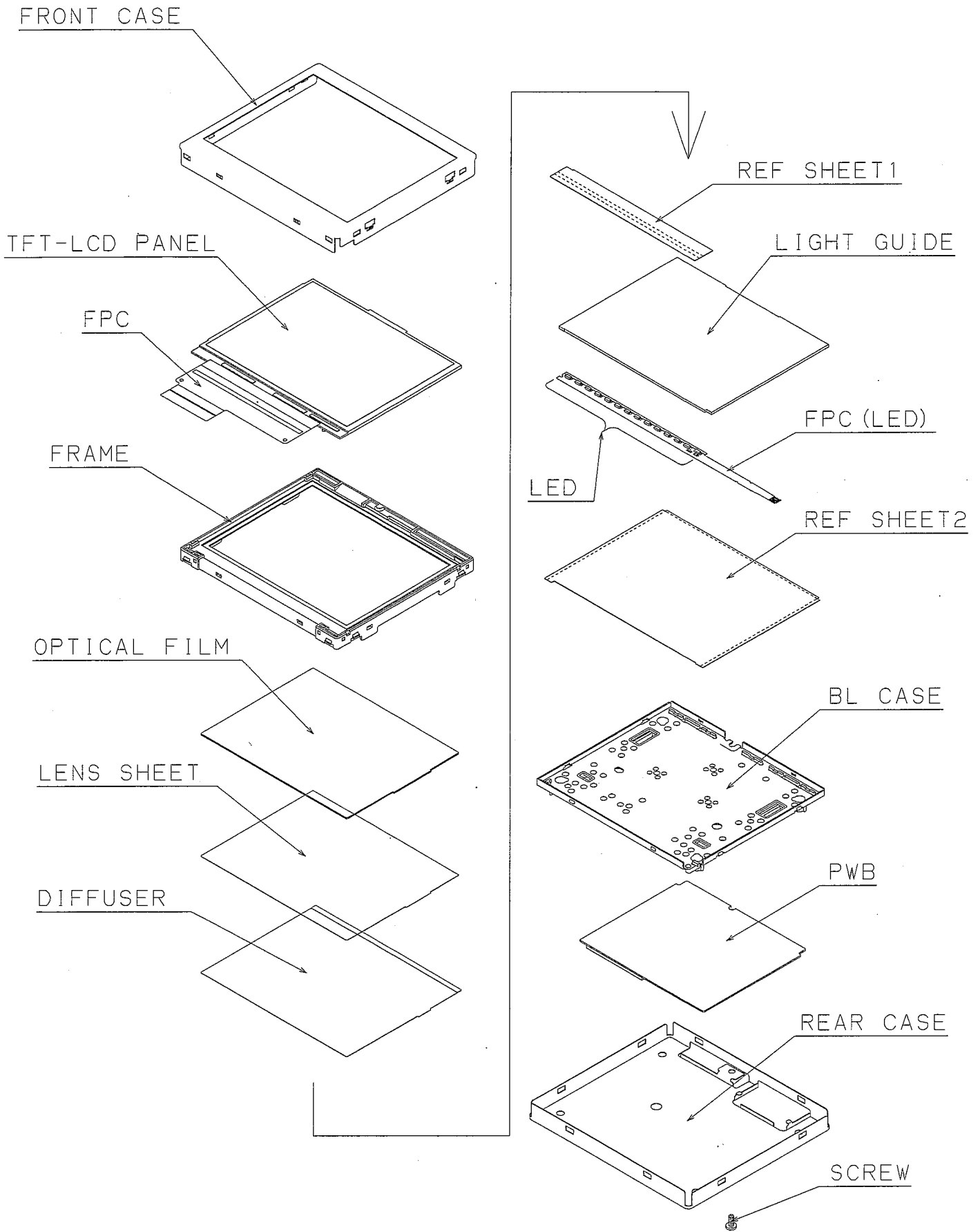

Fig. 2 STRUCTURE OF THE MODULE

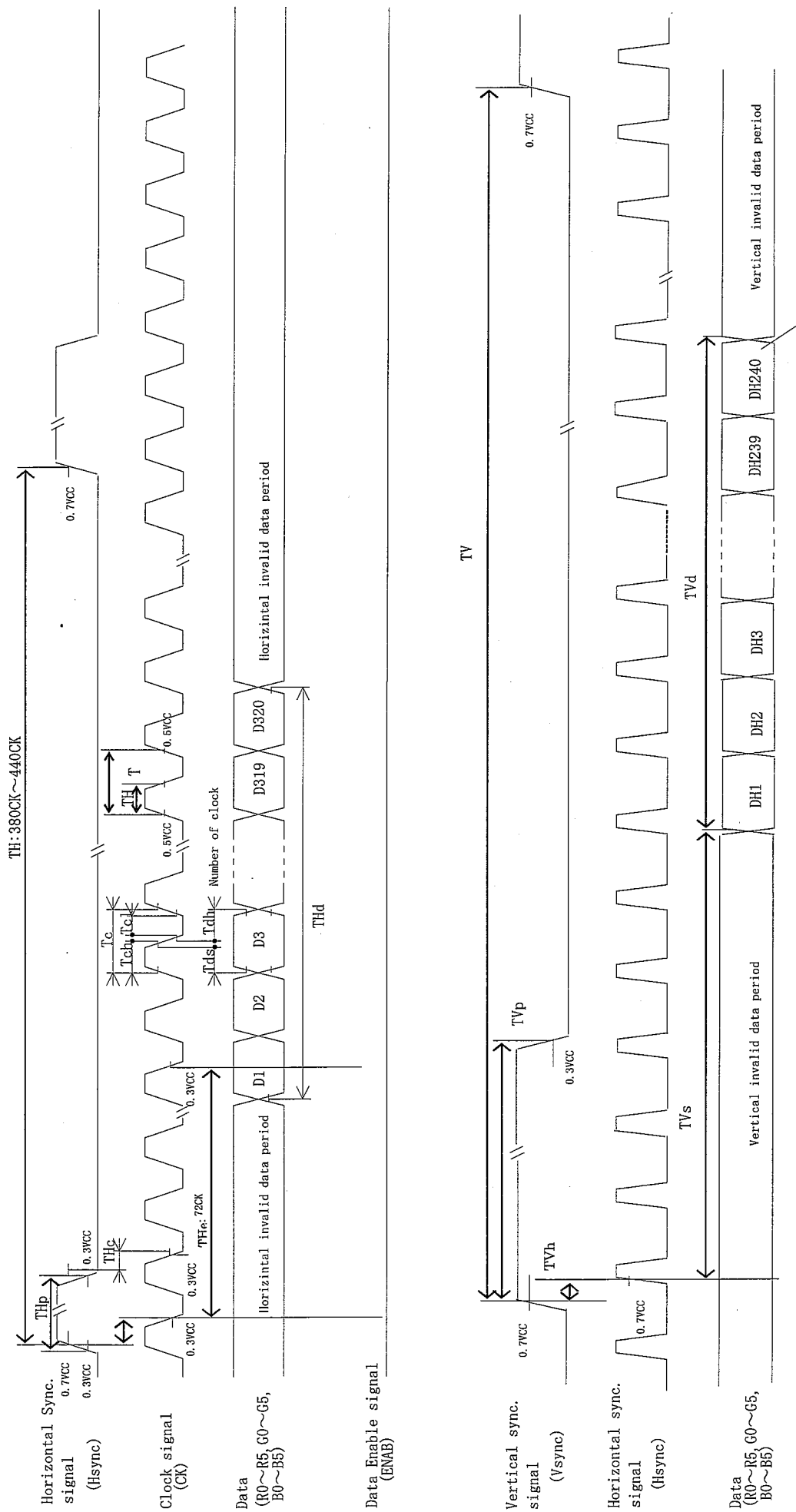

Fig3-B Input signal waveforms (ENAB=" LOW")

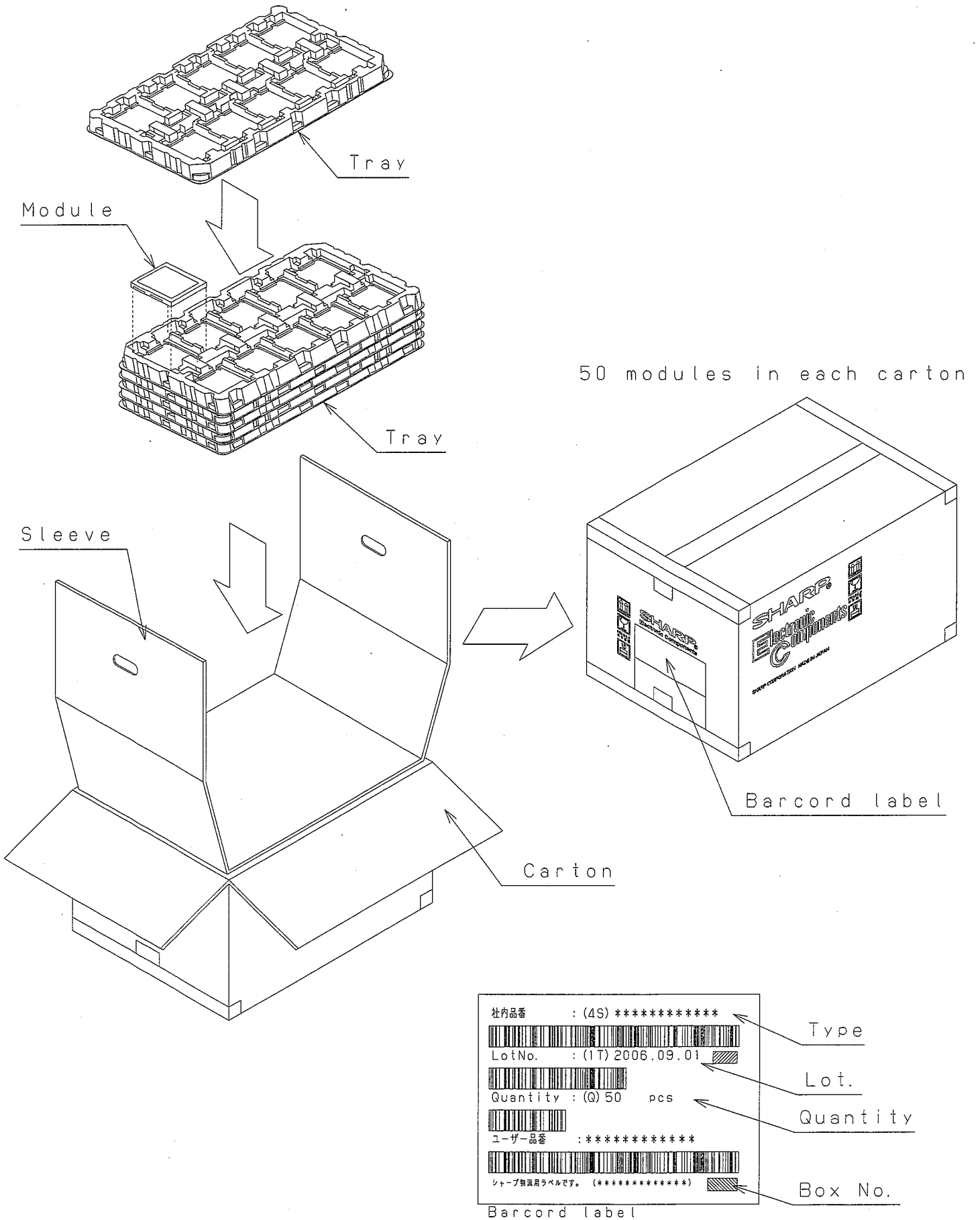

Fig.2 PACKING FORM