

**SHARP**

No.	<b>LD - 20754A</b>
DATE	Jan . 23 . 2009

TECHNICAL LITERATURE  
FOR  
TFT - LCD module

**These parts have corresponded with the RoHS directive.**

MODEL No. LQ084S3LG02

The technical literature is subject to change without notice.  
So, please contact SHARP or its representative before designing  
your product based on this literature.

**Engineering department  
MOBILE LIQUID CRYSTAL DISPLY DIVISION  
MOBILE LIQUID CRYSTAL DISPLY GROUP  
SHARP CORPORATION**



## 1. Application

This technical literature applies to color TFT-LCD module, LQ084S3LG02

These technical literature sheets are the proprietary product of SHARP CORPORATION("SHARP) and include materials protected under copyright of SHARP. Do not reproduce or cause any third party to reproduce them in any form or by any means, electronic or mechanical, for any purpose, in whole or in part, without the express written permission of SHARP.

The device listed in these technical literature sheets was designed and manufactured for use in general electronic equipment.

In case of using the device for applications such as control and safety equipment for transportation (control of aircraft, trains, automobiles, etc.), rescue and security equipment and various safety related equipment which require higher reliability and safety, take into consideration that appropriate measures such as fail-safe functions and redundant system design should be taken.

Do not use the device for equipment that requires an extreme level of reliability, such as aerospace applications, telecommunication equipment (trunk lines), nuclear power control equipment and medical or other equipment for life support.

SHARP assumes no responsibility for any damage resulting from the use of the device which does not comply with the instructions and the precautions specified in these technical literature sheets.

Confirm "11. Handling Precautions " item when you use the device.

Contact and consult with a SHARP sales representative for any questions about this device.

## 2. Overview

This module is a color active matrix LCD module incorporating amorphous silicon TFT (Thin Film Transistor). It is composed of a color TFT-LCD panel, driver ICs, control circuit and power supply circuit and a backlight unit. Graphics and texts can be displayed on a 800×3×600 dots panel with about 16 million colors by using LVDS (Low Voltage Differential Signaling) system for interface and supplying +3.3V DC supply voltage for TFT-LCD panel driving and supply voltage for backlight.

This module is the type of wide viewing angle the viewing angle is 12 o'clock direction.

Backlight-driving DC/AC inverter is not built in this module.

## 3. Mechanical Specifications

Parameter	Specifications	Unit
Display size	21.3 (8.4") Diagonal	cm
Active area	170.4(H) × 127.8(V)	mm
Pixel format	800(H) × 600(V)	pixel
	(1 pixel = R + G + B dots)	
Pixel pitch	0.213(H) × 0.213(V)	mm
Pixel configuration	R,G,B vertical stripe	
Display mode	Normally white	
Unit outline dimensions *1	199.5(W) × 149.5(H) × 12.0max(D)	mm
Mass	MAX.450	g
Surface treatment	Anti-glare and hard-coating 2H	

\*1 : excluding backlight cables.

Outline dimensions is shown in Fig.1

## 4. Input Terminals

## 4-1. TFT-LCD panel driving

CN1 (LVDS Signals , +3.3V DC power supply and Control signal)

Corresponding connector: DF19G20S-1C・・・HIROSE

Pin No.	Symbol	Function	Remark
1	V <sub>CC</sub>	+3.3V power supply	
2	V <sub>CC</sub>	+3.3V power supply	
3	GND		
4	GND		
5	RXIN0-	Differential data input, CH0 (negative)	LVDS signal [Note1 ]
6	RXIN0+	Differential data input, CH0 (positive)	LVDS signal [Note1 ]
7	GND		
8	RXIN1-	Differential data input, CH1 (negative)	LVDS signal [Note1 ]
9	RXIN1+	Differential data input, CH1 (positive)	LVDS signal [Note1 ]
10	GND		
11	RXIN2-	Differential data input, CH2 (negative)	LVDS signal [Note1 ]
12	RXIN2+	Differential data input, CH2 (positive)	LVDS signal [Note1 ]
13	GND		
14	RXCLK IN-	Differential clock input (negative)	LVDS signal [Note1 ]
15	RXCLK IN+	Differential clock input (positive)	LVDS signal [Note1 ]
16	GND		
17	RXIN3-	Differential data input, CH3 (negative)	LVDS signal [Note1,3 ]
18	RXIN3+	Differential data input, CH3 (positive)	LVDS signal [Note1 ,3]
19	REV	Horizontal/Vertical display mode select signal	[Note 2]
20	8/6Bit	8Bit/6Bit mode select signal	[Note 4]

[Note1 ] To obtain the proper relation between LVDS signals and actual digital data signals, the digital signals should be inputted into the transmitter as described in the next section, 4-2.7-2. The shielding case is connected with signal GND.

[Note 2]

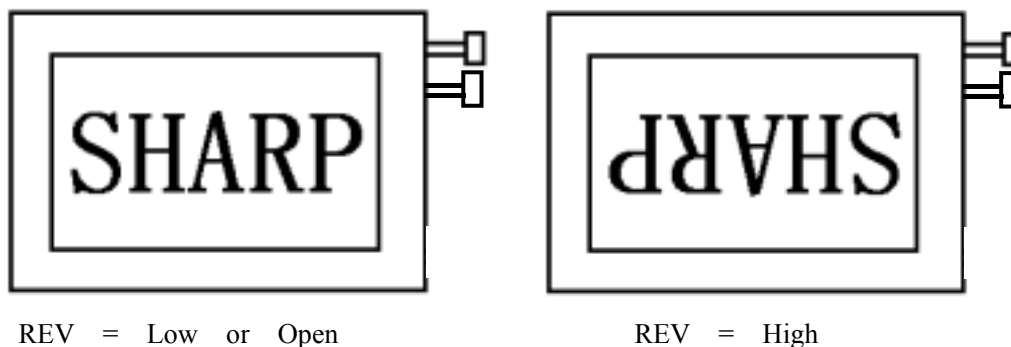

[Note 3] In case of using on 6bit data signals, connect PXIN3- and PXIN3+ to GND terminal.

[Note 4]

8/6Bit= "H"	8Bit mode
8/6Bit= "L" or Open	6Bit mode

## 4-2 LVDS Interface block diagram

Using receiver : Single LVDS interface, which equals THC63LVDF64A(THine),contained in a control IC

Corresponding Transmitter : DS90C363, DS90C363A, DS90C383, DS90C383A (National semiconductor) ,

THC63LVDF63A,THC63LVDM63A(THine), SN75LVDS84(Ti)

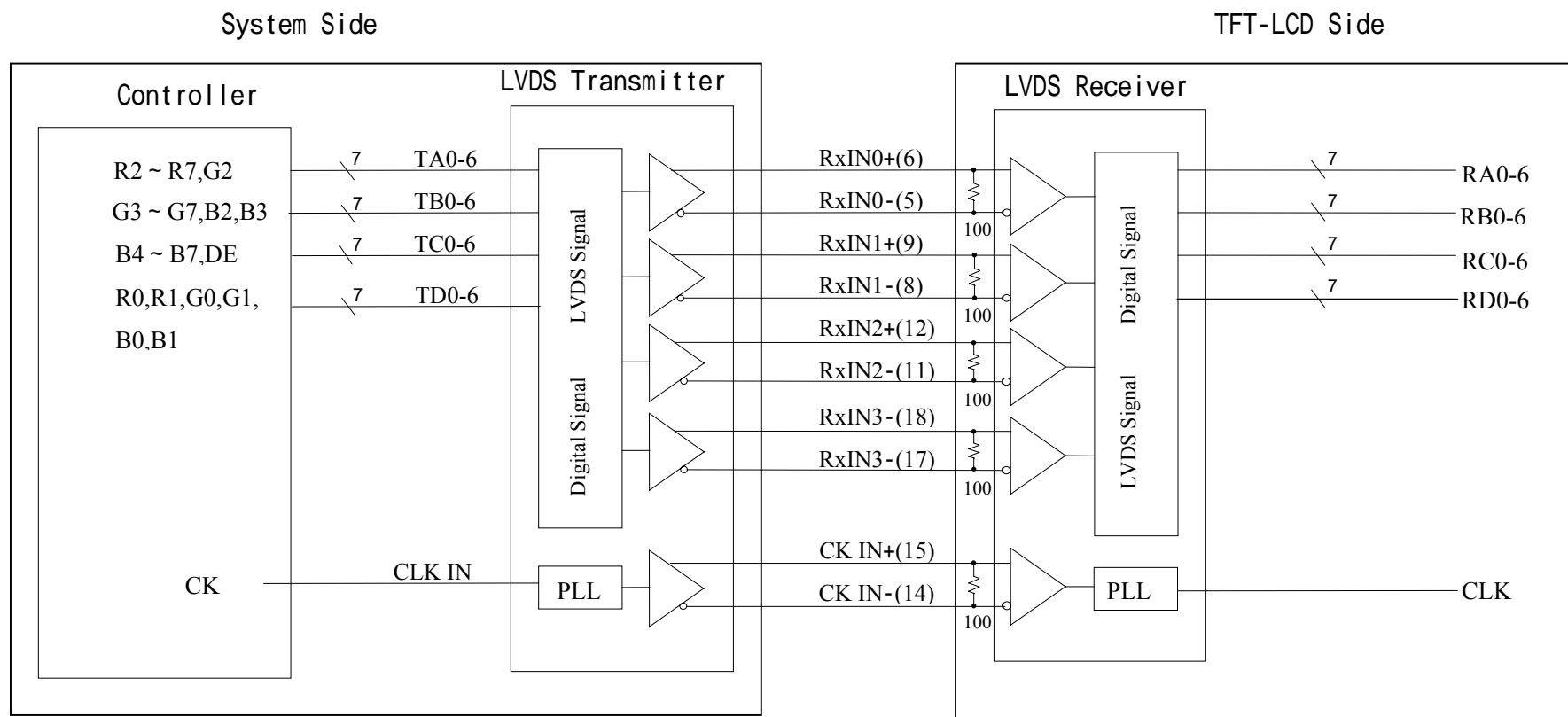

[Note]In case of using on 6bit data signals,connect PXIN3- and PXIN3+ to GND terminal.

## Data Mapping

[ Note ] Thine:THC63LVDM83R

Transmitter		CN1 20pin (8/6bit)	
Pin No.	Data	= "H" (8bit)	= "L" or Open (6bit)
51	TA0	R2	R2 (LSB)
52	TA1	R3	R3
54	TA2	R4	R4
55	TA3	R5	R5
56	TA4	R6	R6
3	TA5	R7(MSB)	R7 (MSB)
4	TA6	G2	G2 (LSB)
6	TB0	G3	G3
7	TB1	G4	G4
11	TB2	G5	G5
12	TB3	G6	G6
14	TB4	G7(MSB)	G7 (MSB)
15	TB5	B2	B2 (LSB)
19	TB6	B3	B3
20	TC0	B4	B4
22	TC1	B5	B5
23	TC2	B6	B6
24	TC3	B7(MSB)	B7 (MSB)
27	TC4	(NA)	(NA)
28	TC5	(NA)	(NA)
30	TC6	DE	DE
50	TD0	R0(LSB)	R0 (GND)
2	TD1	R1	R1 (GND)
8	TD2	G0(LSB)	G0 (GND)
10	TD3	G1	G1 (GND)
16	TD4	B0(LSB)	B0 (GND)
18	TD5	B1	B1 (GND)
25	TD6	(NA)	GND

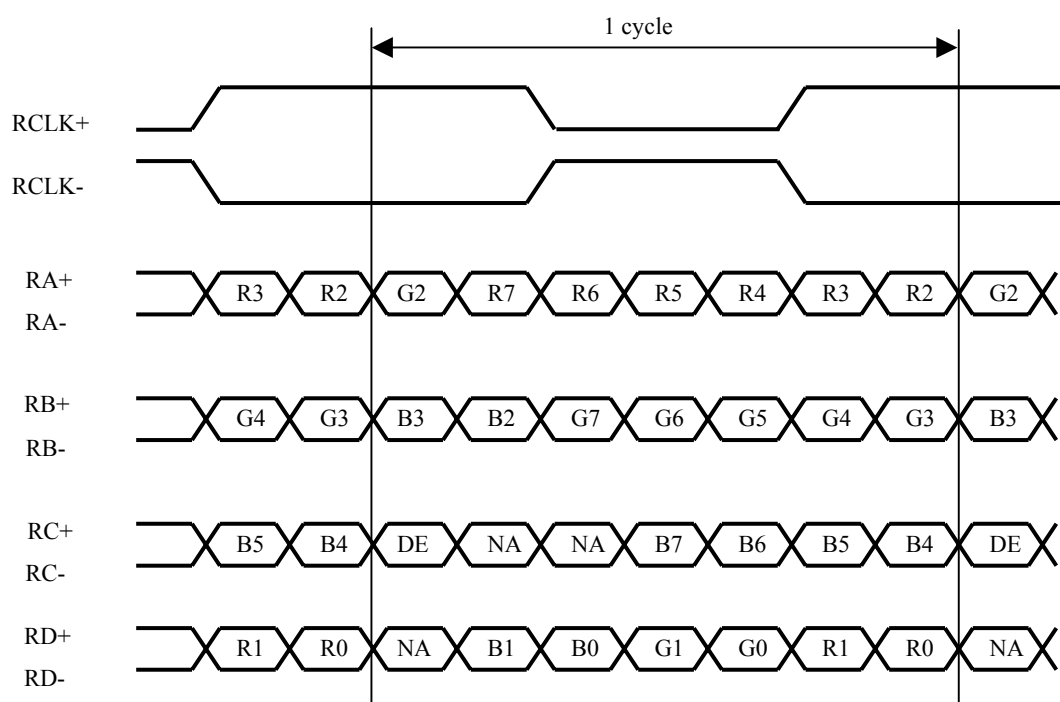

DE : Display Enable

NA : Not Available

#### 4-3. Backlight driving CN2

Using connector : BHR-04VS-1 (JST)  
Corresponding connector : SM04(4.0)B-BHS (JST)

Pin no.	symbol	Function
1	V <sub>HIGH</sub>	Power supply for lamp (High voltage side)
2	V <sub>HIGH</sub>	Power supply for lamp (High voltage side)
3	NC	OPEN
4	V <sub>LOW</sub>	Power supply for lamp (Low voltage side)

[Note] Input voltage into terminal 1 and 2 must be in-pulse.  
Anti-pulse input might cause discharge between terminals.

#### 5. Absolute Maximum Ratings

Parameter	Symbol	Condition	Pin name	Ratings	Unit	Remark
Supply voltage	V <sub>cc</sub>	Ta=25°C	V <sub>cc</sub>	0 to + 4.0	V	
Input voltage	V <sub>I</sub>	Ta=25°C	RXINi-/(i= 0,1,2,3) RXCLK IN-/+ , REV , 8/6Bit	-0.3 to V <sub>cc</sub> +0.3	V	
Storage temperature	T <sub>stg</sub>	-	-	-30 to +80	°C	[Note1]
Operating temperature	T <sub>ops</sub>	Panel surface	-	-30 to +80	°C	[Note2]

【Note1】 Humidity : 95%RH Max. at Ta 40 .

Maximum wet-bulb temperature at 39 or less at Ta>40 . ( No condensation. )

【Note2】 There is a possibility of causing deterioration in the irregularity and others of the screen and the display fineness when preserving or using it from 65 to 80 .

#### 6. Electrical Characteristics

##### 6-1. TFT-LCD panel driving

Ta=25°C

Parameter	Symbol	Min.	Typ.	Max.	Unit	Remark	
Supply voltage	V <sub>cc</sub>	+3.0	+3.3	+3.6	V	[Note5]	
Current dissipation	I <sub>cc</sub>	-	(300)	(380)	mA	[Note6]	
Permissive input ripple voltage	VRP	-	-	100	mVp-p	V <sub>cc</sub> =3.3V	
Input voltage range	V <sub>L</sub>	0	-	2.4	V	LVDS signal	
Differential input threshold voltage	High	V <sub>TH</sub>	-	-	+100	mV	V <sub>CM</sub> =1.2V
	Low	V <sub>TL</sub>	-100	-	-	mV	[Note1]
Input impedance (Differential input)	R <sub>T</sub>	-	100	-			
Input current	High	IOH1	-	-	± 10	uA	[Note2]
		IOH2	-	-	± 500	uA	[Note3]
Input current	Low	IOL1	-	-	± 10	uA	[Note2]
		IOL2	-	-	± 500	uA	[Note4]

[Note1] V<sub>CM</sub> : Common mode voltage of LVDS driver.

[Note2] REV , 8/6Bit

[Note3] V<sub>L</sub> = +2.4V、 V<sub>CC</sub> = +3.6V

[Note4] V<sub>L</sub> = 0V、 V<sub>CC</sub> = +3.6V

[Note5] On-off conditions for supply voltage

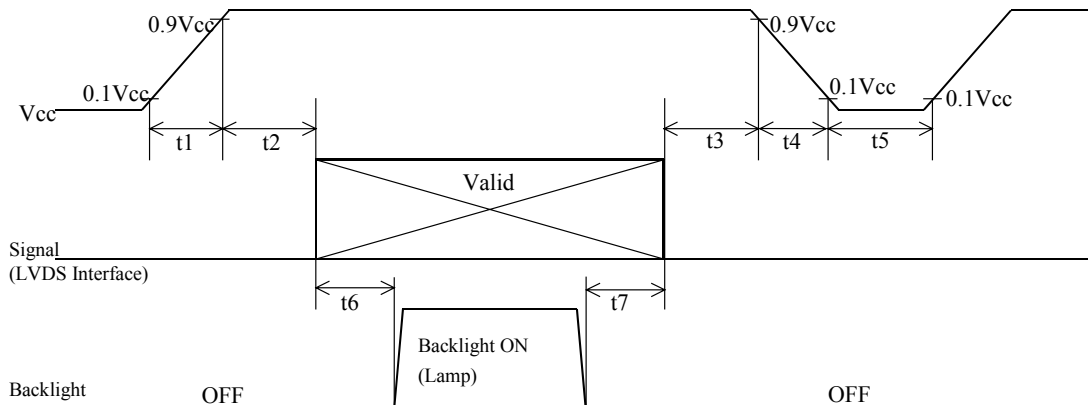

Symbol	Min.	Typ.	Max.	Remark
t1	0	25	ms	
t2	0	100	ms	
t3	0	1	s	
t4	0	400	ms	
t5	200	-	ms	
t6	180	-	ms	*1
t7	5	-	ms	*1

\*1 It is recommended to consider something difference between LVDS input and Back-light Input as shown above.

If the Back-lights light on before LCD starting ,or if the Back-lights is kept on after LCD stopping, The screen may look white for a moment or abnormal image may be displayed.

This is caused by variation in output signal from timing generator at LVDS input on or off. It dose not cause the damage to the LCD module.

Vcc-dip conditions

- 1) 2.5V Vcc
- td 10ms
- 2) Vcc<2.5V

Vcc-dip conditions should also follow the On-off conditions for supply voltage

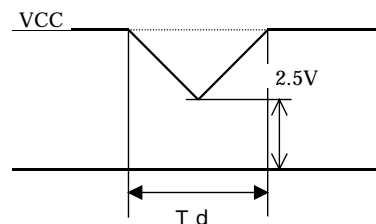

[Note6] Typical current situation : 16-gray-bar pattern.

Vcc=+3.3V

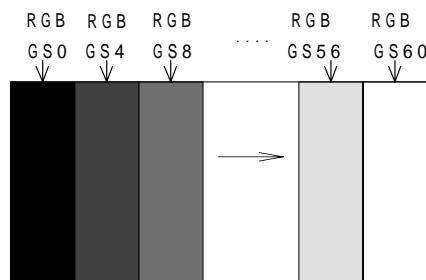

## 6-2. Backlight driving

The backlight system is an edge-lighting type with double CCFT (Cold Cathode Fluorescent Tube).

The characteristics of single lamp are shown in the following table.

(It is usually required to measure under the following condition.  $I_L=6.0\text{mA}$ ,  $T_a=25^\circ\text{C} \pm 2^\circ\text{C}$ ,  $F_L=60\text{kHz}$ .)

Parameter	Symbol	Min.	Typ.	Max.	Unit	Remark
Lamp current	$I_L$	3.0	6.0	6.5	mA rms	[Note1]
Lamp voltage	$V_L$	-	(380)	-	V rms	
Lamp power consumption	$P_L$	-	(2.3)	-	W	[Note2]
Lamp frequency	$F_L$	(45)		(100)	kHz	[Note3]
Kick-off voltage	$V_s$	-	-	(890)	V rms	$T_a=25^\circ\text{C}$
		-	-	(1000)	V rms	$T_a=-30^\circ\text{C}$

[Note1] Lamp current is measured with current meter for high frequency as shown below.

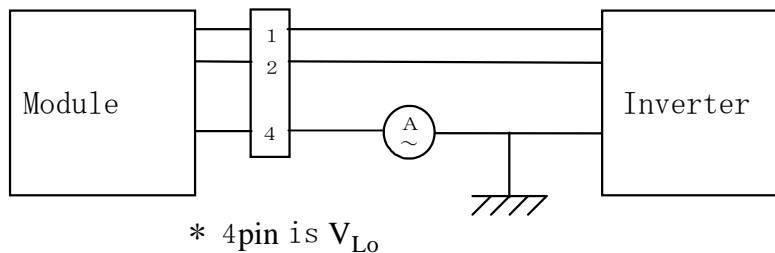

[Note2] Referential data per one CCFT by calculation. ( $I_L \times V_L$ )

The data don't include loss at inverter. ( $I_L = 6.0\text{mA rms}$ )

[Note3] Lamp frequency may produce interference with horizontal synchronous frequency, and this may cause beat on the display. Therefore lamp frequency shall be detached as much as possible from the horizontal synchronous frequency and from the harmonics of horizontal synchronous to avoid interference.

[Note4] The open output voltage of the inverter shall be maintained for more than 1s; otherwise the lamp may not be turned on.

[Note5] Lamp is consumables. In the following condition, the life time is 50,000 hour as the reference value and it is not guaranteed in this technical literature sheets by SHARP.

Above value is applicable when lamp is placed horizontally.

Lamp life time is defined that it applied either ① or ② under this condition.

(Continuous turning on at  $T_a = 25^\circ\text{C}$ ,  $I_L = 6.0\text{mA rms}$ )

① Brightness becomes 50% of the original value under standard condition.

② Kick-off voltage at  $T_a = -30^\circ\text{C}$  exceeds maximum value (1000Vrms).

Lamp life time shortens according to the state of mounting and use.

(Lamp lifetime may vary if lamp is in portrait position due to the change of mercury density inside the lamp.)

In case of operating under lower temp environment, the lamp exhaustion is accelerated and the brightness becomes lower.

Continuous operating for around 1 month under lower temp condition may reduce the brightness to half of the original brightness.

In case of such usage under lower temp environment, periodical lamp exchange is recommended.

[Note6] The performance of the backlight, for example life time or brightness, is much influenced by the characteristics of the DC-AC inverter for the lamp.

When you design or order the inverter, please make sure that a poor lighting caused by the mismatch of the backlight and the inverter (miss-lighting, flicker, etc.) never occur. when you confirm it, the module should be operated in the same condition as it is installed in your instrument.

Be sure to use a back light power supply with the safety protection circuit such as the detection circuit for the excess voltage, excess current and or electric discharge waveform.

Be sure to use the detect circuit by which one side of the CCFT lamps can be controlled independently.

Otherwise, when one side of the CCFT is open, the excess current may possibly be applied to the other side of the lamp.

[Note7] It is required to have the inverter designed so that to allow the impedance deviation of the two CCFT lamps and the capacity deviation of barast capacitor.

[Note8] Please make it to the structure not touching directly insulating the high voltage part.

Please stop the circuit by the protection element such as fuses for generation of heat and the ignition prevention, and use a flame resisting and high material for the substrate and the resin material.

[Note9] Under the environment of 10lx or less, miss-lighting delay may occur.

7. Timing characteristics of input signals

7-1. Timing characteristics

Parameter		Symbol	Min.	Typ.	Max.	Unit	Remark
Clock signal	Frequency	1/Tc	35	40	42	MHz	
ENAB signal	Horizontal Frequency	TH	832	1056	1395	clock	
			20.8	26.4	39.9	μs	
	Horizontal period (High)	THd	800	800	800	clock	
	Vertical period	TV	628	666	798	line	【注1】
			-	17.6	-	ms	
Vertical period (High)	TVd	600	600	600	line		

【Note】 In case of using the long vertical period, the deterioration of display quality, flicker etc. may occur.

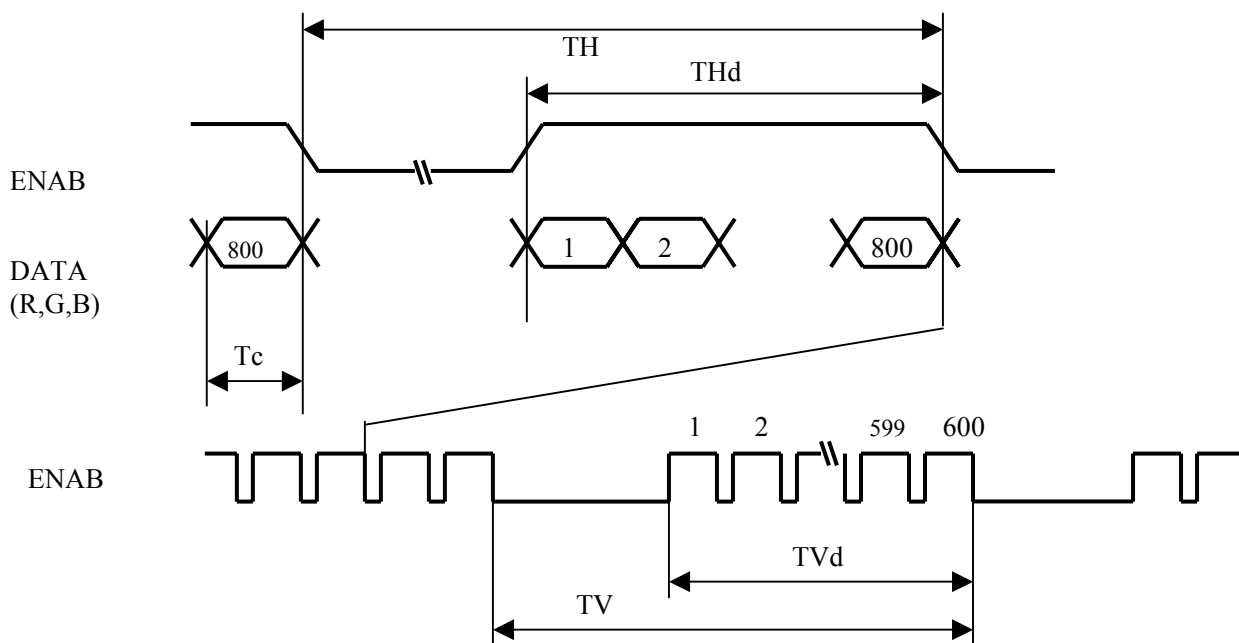

7-2. Input Data Signals and Display Position on the screen

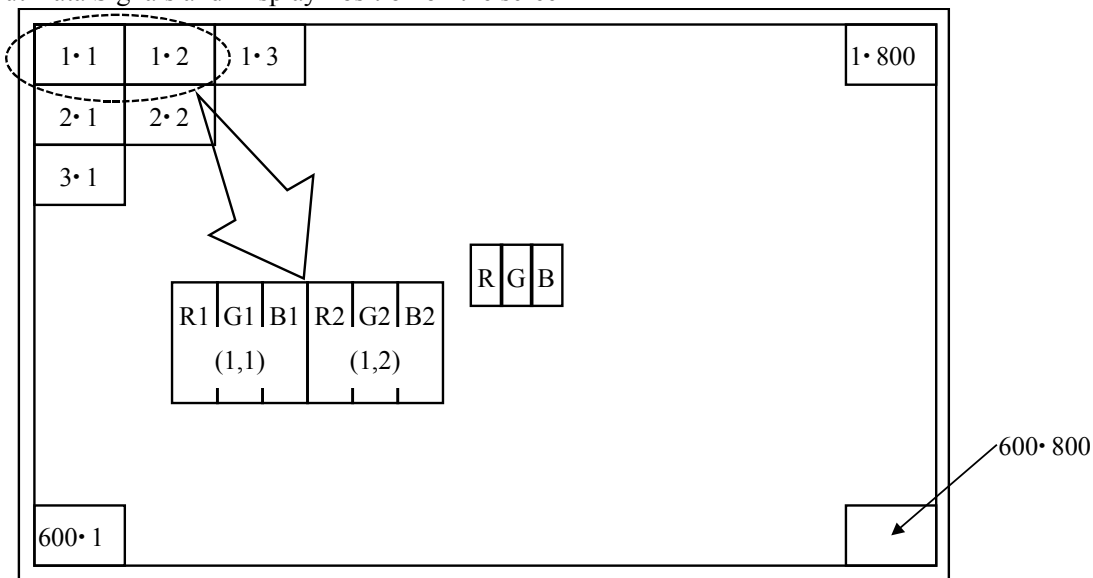

Display Position of Data (V·H)

## 8. Input Signals, Basic Display Colors and Gray Scale of Each Color

	Colors & Gray scale	Data signal																								
		Gray Scale	R0	R1	R2	R3	R4	R5	R6	R7	G0	G1	G2	G3	G4	G5	G6	G7	B0	B1	B2	B3	B4	B5	B6	B7
Basic Color	Black	-	0	0	0	0	0	0	0	0	0	0	0	0	0	0	0	0	0	0	0	0	0	0	0	0
	Blue	-	0	0	0	0	0	0	0	0	0	0	0	0	0	0	0	0	X	X	1	1	1	1	1	1
	Green	-	0	0	0	0	0	0	0	0	X	X	1	1	1	1	1	1	0	0	0	0	0	0	0	0
	Cyan	-	0	0	0	0	0	0	0	0	X	X	1	1	1	1	1	1	X	X	1	1	1	1	1	1
	Red	-	X	X	1	1	1	1	1	1	0	0	0	0	0	0	0	0	0	0	0	0	0	0	0	0
	Magenta	-	X	X	1	1	1	1	1	1	0	0	0	0	0	0	0	0	X	X	1	1	1	1	1	1
	Yellow	-	X	X	1	1	1	1	1	1	X	X	1	1	1	1	1	1	0	0	0	0	0	0	0	0
	White	-	X	X	1	1	1	1	1	1	X	X	1	1	1	1	1	1	X	X	1	1	1	1	1	1
Gray Scale of Red	Black	GS0	0	0	0	0	0	0	0	0	0	0	0	0	0	0	0	0	0	0	0	0	0	0	0	0
	↑	GS1	1	0	0	0	0	0	0	0	0	0	0	0	0	0	0	0	0	0	0	0	0	0	0	0
	Darker	GS2	0	1	0	0	0	0	0	0	0	0	0	0	0	0	0	0	0	0	0	0	0	0	0	0
	↑	↓					↓							↓								↓				
	↓	↓					↓							↓								↓				
	Brighter	GS250	0	1	0	1	1	1	1	1	0	0	0	0	0	0	0	0	0	0	0	0	0	0	0	0
	↓	GS251	1	1	0	1	1	1	1	1	0	0	0	0	0	0	0	0	0	0	0	0	0	0	0	0
	Red	GS252	X	X	1	1	1	1	1	1	0	0	0	0	0	0	0	0	0	0	0	0	0	0	0	0
Gray Scale of Green	Black	GS0	0	0	0	0	0	0	0	0	0	0	0	0	0	0	0	0	0	0	0	0	0	0	0	0
	↑	GS1	0	0	0	0	0	0	0	0	1	0	0	0	0	0	0	0	0	0	0	0	0	0	0	0
	Darker	GS2	0	0	0	0	0	0	0	0	0	1	0	0	0	0	0	0	0	0	0	0	0	0	0	0
	↑	↓					↓							↓								↓				
	↓	↓					↓							↓								↓				
	Brighter	GS250	0	0	0	0	0	0	0	0	0	1	0	1	1	1	1	1	0	0	0	0	0	0	0	0
	↓	GS251	0	0	0	0	0	0	0	0	1	1	0	1	1	1	1	1	0	0	0	0	0	0	0	0
	Green	GS252	0	0	0	0	0	0	0	0	X	X	1	1	1	1	1	1	0	0	0	0	0	0	0	0
Gray Scale of Blue	Black	GS0	0	0	0	0	0	0	0	0	0	0	0	0	0	0	0	0	0	0	0	0	0	0	0	0
	↑	GS1	0	0	0	0	0	0	0	0	0	0	0	0	0	0	0	0	1	0	0	0	0	0	0	0
	Darker	GS2	0	0	0	0	0	0	0	0	0	0	0	0	0	0	0	0	0	1	0	0	0	0	0	0
	↑	↓					↓							↓								↓				
	↓	↓					↓							↓								↓				
	Brighter	GS250	0	0	0	0	0	0	0	0	0	0	0	0	0	0	0	0	0	1	0	1	1	1	1	1
	↓	GS251	0	0	0	0	0	0	0	0	0	0	0	0	0	0	0	0	1	1	0	1	1	1	1	1
	Blue	GS252	0	0	0	0	0	0	0	0	0	0	0	0	0	0	0	0	X	X	1	1	1	1	1	1

0 : Low level voltage,      1 : High level voltage.      X : Don't care

Each basic color can be displayed in 253 gray scales from 8 bit data signals. According to the combination of total 24 bit data signals, the 16-million-color display can be achieved on the screen.

9. Optical Characteristics

Ta=25 , Vcc=+3.3V

Parameter		Symbol	Condition	Min.	Typ.	Max.	Unit	Remark
Viewing angle range	Horizontal	21, 22	CR>10	50	65	-	Deg.	[Note1]
	Vertical	11		45	60	-	Deg.	[Note4]
		12		40	55	-	Deg.	[Note4]
Contrast ratio		CRn	Optimum viewing angle	300	450	-		[Note2] [Note4]
Response time		r+ d	=0°	-	35	-	ms	[Note3] [Note4]
Chromaticity of white		x		0.263	0.313	0.363		[Note4]
		y		0.279	0.329	0.379		I <sub>L</sub> =6.0mA rms
Luminance of white		Y <sub>L</sub>			350	-	cd/m <sup>2</sup>	F <sub>L</sub> =60kHz
White Uniformity		δ <sub>w</sub>		-	-	1.33		[Note5]

[Note] The measurement shall be executed 30 minutes after lighting at rating. (condition:I<sub>L</sub>=6.0mA rms)  
 The optical characteristics shall be measured in a dark room or equivalent state with the method shown in Fig.2 below.

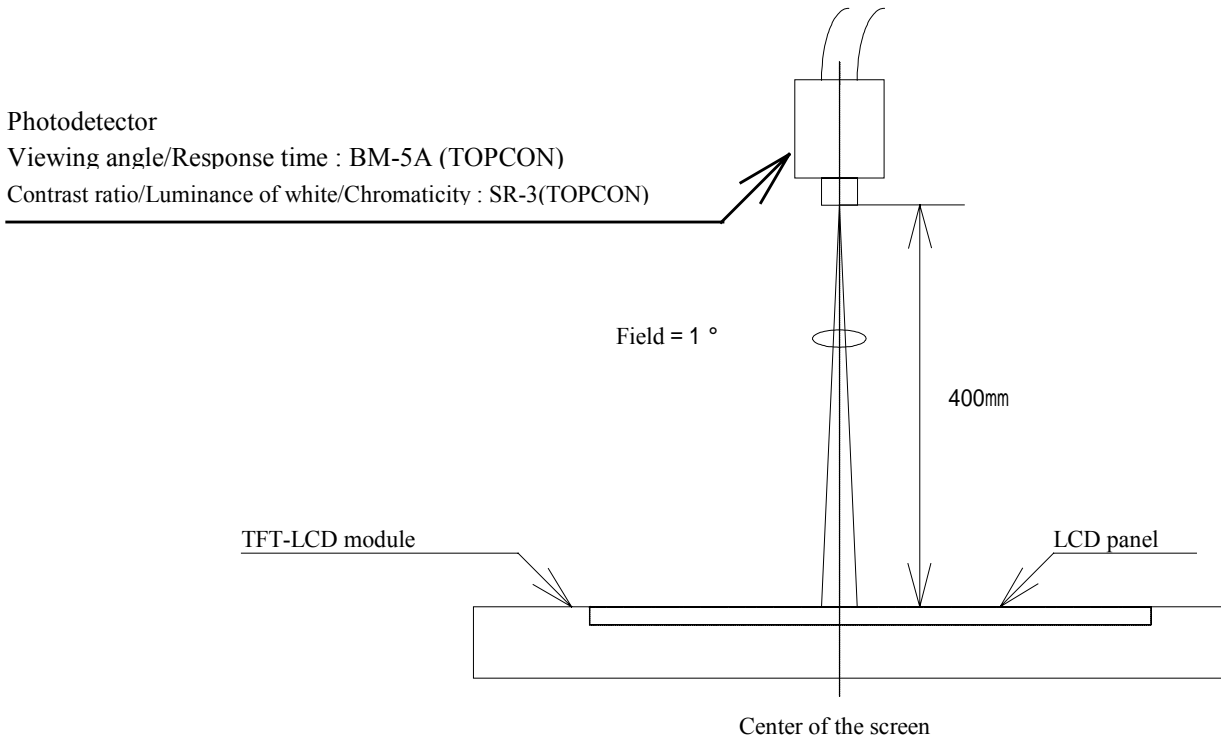
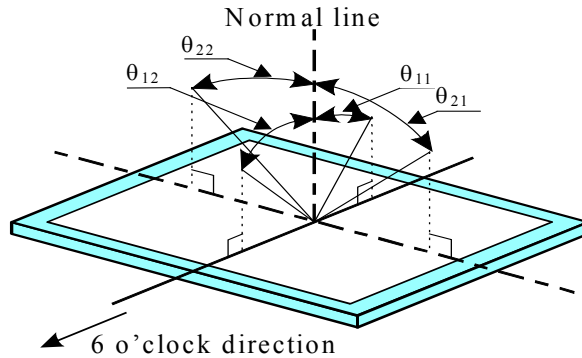

Fig.2 Optical characteristics measurement method

[Note1] Definitions of viewing angle range:



[Note2] Definition of contrast ratio:

The contrast ratio is defined as the following.

$$\text{Contrast Ratio (CR)} = \frac{\text{Luminance (brightness) with all pixels white}}{\text{Luminance (brightness) with all pixels black}}$$

[Note3] Definition of response time:

The response time is defined as the following figure and shall be measured by switching the input signal for "black" and "white" .

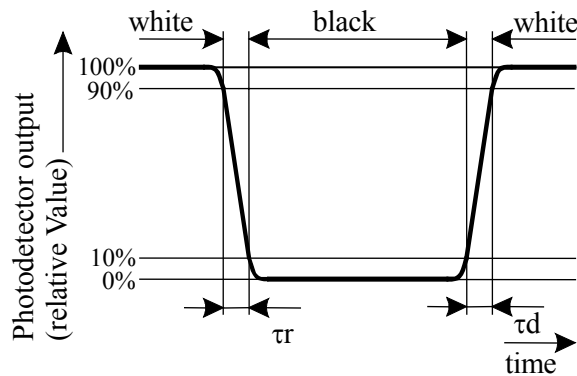

[Note4] This shall be measured at center of the screen.

[Note5] Definition of white uniformity:

White uniformity is defined as the following with five measurements (A ~ E).

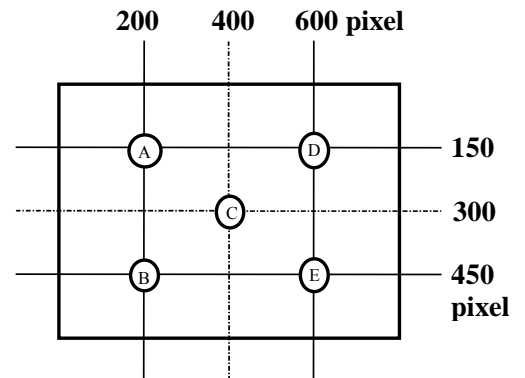

$$w = \frac{\text{Maximum Luminance of five points (brightness)}}{\text{Minimum Luminance of five points (brightness)}}$$

10. Display Quality

The display quality of the color TFT-LCD module shall be in compliance with the Incoming Inspection Standard.

## 11. Handling Precautions

- a) Be sure to turn off the power supply when inserting or disconnecting the cable.
- b) Be sure to design the cabinet so that the module can be installed without any extra stress such as warp or twist.
- c) Since the front polarizer is easily damaged, pay attention not to scratch it.  
Blow away dust on the polarizer with antistatic N<sub>2</sub> blow. It is undesirable to wipe off because a polarizer is sensitive.  
It is recommended to peel off softly using the adhesive tape when soil or finger oil is stuck to the polarizer.  
When unavoidable, wipe off carefully with a cloth for wiping lenses.
- d) Wipe off water drop immediately. Long contact with water may cause discoloration or spots.
- e) When the panel surface is soiled, wipe it with absorbent cotton or other soft cloth.
- f) Since the panel is made of glass, it may break or crack if dropped or bumped on hard surface. Handle with care.
- g) Since CMOS LSI is used in this module, take care of static electricity and injure the human earth when handling. Observe all other precautionary requirements in handling components.
- h) Since there is a circuit board in the module back, stress is not added at the time of a design assembly.  
Please make it like. If stress is added, there is a possibility that circuit parts may be damaged.
- i) Protection film is attached to the module surface to prevent it from being scratched .  
Peel the film off slowly , just before the use, with strict attention to electrostatic charges.  
Blow off 'dust' on the polarizer by using an ionized nitrogen.
- j) The polarizer surface on the panel is treated with Anti-Glare for low reflection. In case of attaching protective board over the LCD, be careful about the optical interface fringe etc. which degrades display quality.
- k) Do not expose the LCD panel to direct sunlight. Lightproof shade etc. should be attached when LCD panel is used under such environment. The panel characteristic might be deteriorated and the display fineness decrease when strong light is irradiated to the liquid crystal panel.
- l) Connect GND to 4 place of mounting holes to stabilize against EMI and external noise.
- m) There are high voltage portions on the backlight and very dangerous. Careless touch may lead to electrical shock.  
When exchange lamps or service, turn off the power without fail.
- n) When handling LCD modules and assembling them into cabinets, please avoid that long-terms storage in the environment of oxidization or deoxidization gas and the use of such materials as reagent, solvent, adhesive, resin, etc. which generate these gasses, may cause corrosion and discoloration of the modules.
- o) Cold cathode fluorescent lamp in LCD panel contains a small amount of mercury, please follow local ordinances or regulations for disposal.
- p) Be careful of a back light lead not to pull by force at the time of the wiring to an inverter, or line processing.
- q) When install LCD modules in the cabinet, please tighten with “torque =  $0.294 \pm 0.02\text{N} \cdot \text{m}$  ( $3.0 \pm 0.2\text{kgf} \cdot \text{cm}$ )”.  
Be sure to confirm it in the same condition as it is installed in your instrument.
- r) Liquid crystal contained in the panel may leak if the LCD is broken. Rinse it as soon as possible if it gets inside your eye or mouth by mistake.
- s) Notice : Never dismantle the module , because it will cause failure. Please don't remove the fixed tape, insulating tape etc that was pasted on the original module. (except for protection film of the panel and the crepe tape(yellow tape) of fixing lamp cable temporarily.)
- t) Be careful when using it for long time with fixed pattern display as it may cause afterimage.  
(Please use a screen saver etc., in order to avoid an afterimage.)
- u) Adjusting volume have been set optimally before shipment, so do not change any adjusted value.  
If adjusted value is changed, the specification may not be satisfied.
- v) If a minute particle enters in the module and adheres to an optical material, it may cause display non-uniformity issue, etc.  
Therefore, fine-pitch filters have to be installed to cooling and inhalation hole if you intend to install a fan.

w)The lamp used for this product is very sensitive to the temperature.

Luminance decreases rapidly when it is used for a long time or repeatedly under the environment of the low temperature or the module is being cooled.

Please avoid the continuous or repeating use of it under such an environment.

It may decrease up to 50% of the initial luminance in about one month under the low temperature environment.

Please consult our company when it is used under the environment like the above mentioned.

## 12. Packing form

Product countries / Areas	JAPAN	CHINA
Piling number of cartons	6(Max)	
Package quantity in one carton	10pcs	
Carton size	408mm (W) × 203mm (H) × 244mm (D)	
Total mass of one carton filled with full modules	6kg (max)	
Packing form is shown	Fig.3	

## 13 . Reliability test items

No.	Test item	Conditions	Remark
1	High temperature storage test	Ta=80 240h	
2	Low temperature storage test	Ta= -30 240h	
3	High temperature operation test	Ta=80 240h	
4	Low temperature operation test	Ta= -30 240h	
5	High temperature & high humidity operation test	Ta=40 ; 95%RH 240h (No condensation)	
6	Vibration test (non- operating)	Frequency: 10 ~ 57Hz/Vibration width (one side):0.153mm : 57 ~ 500Hz/Gravity:19.6m/s <sup>2</sup> Sweep time : 11 minutes Test period : 3 hours (1 hour for each direction of X,Y,Z)	
7	Shock test (non- operating)	Max. gravity : 490m/s <sup>2</sup> Pulse width : 11ms, half sine wave Direction : ± X, ± Y, ± Z once for each direction.	
8	ESD test	Contact discharge (150pF 330 ) non-operating = ± 10kV, operating = ± 8kV Atmospheric discharge (150pF 330 ) non-operating = ± 20kV, operating = ± 15kV	
9	EMI	Measurement in 10m site	VCCI (Class B)

### [Result Evaluation Criteria]

Under the display quality test conditions with normal operation state, these shall be no change which may affect practical display function. (normal operation state : Temperature:15 ~ 35 , Humidity:45 ~ 75% , Atmospheric pressure:86 ~ 106kpa)

14.Others

14-1. Label

Lot No. Label:

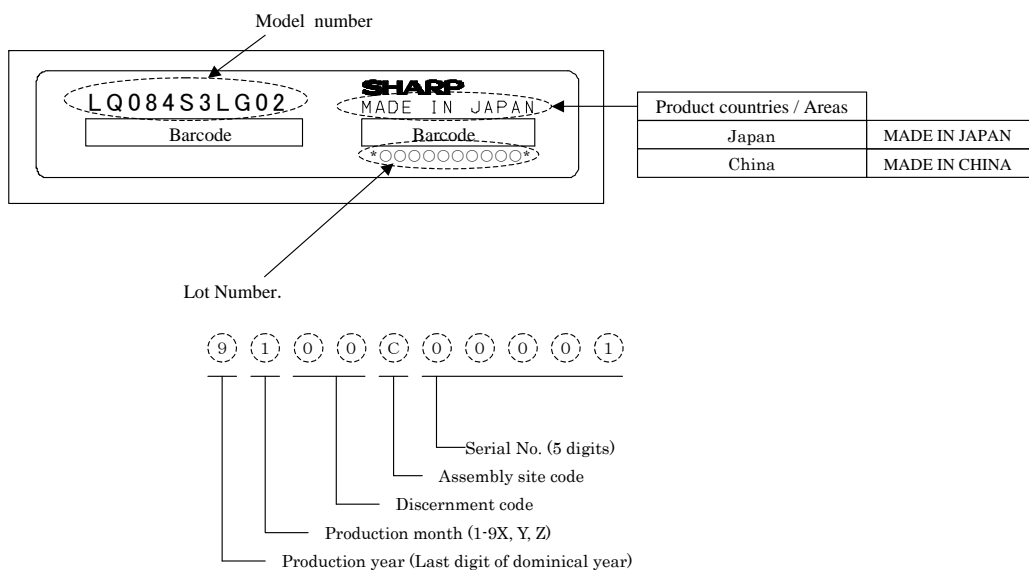

Packing box Label:

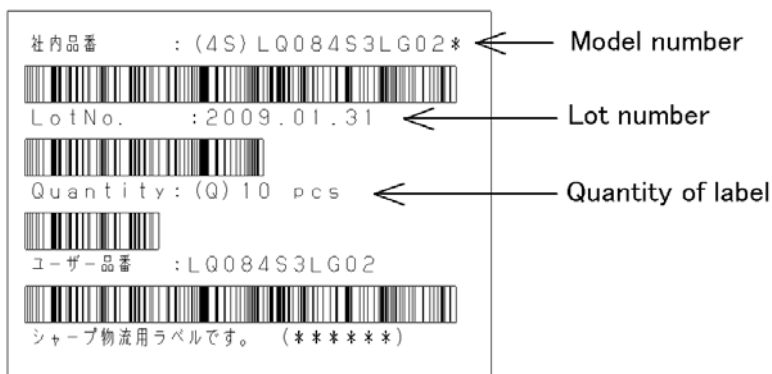

The figure right below is written to the packing box of the settlement for the RoHS restriction.  
 R.C. (RoHS Compliance) means it suits the RoHS directive.  
 This LCD module is compliant with RoHS Directive.

Internal Use Only  
R. C.

14-2. If any problem occurs in relation to the description of this specification, it shall be resolved through discussion with spirit of cooperation.

## 15. Storage conditions

<Environmental condition range of storage temperature and humidity>

Temperature 0 to 40 degrees Celsius

Relative humidity 95% and below

[Note] Please refer below as a mean value of the environmental conditions.

Summer time temperature 20 to 35 degrees Celsius

humidity 85% and below

Winter time temperature 5 to 15 degrees Celsius

humidity 85% and below

Please maintain within 240 hours of accumulated length of storage time, with conditions of 40 degrees Celsius and room humidity of 95%.

### Direct sun light

Please keep the product in a dark room or cover the product to protect from direct sun light.

### Atmospheric condition

Please refrain from keeping the product with possible corrosive gas or volatile flux.

### Prevention of dew

\* Please store the product carton either on a wooden pallet or a stand / rack to prevent dew.

Do not place directly on the floor. In addition, to obtain moderate ventilation in between the pallet's top and bottom surfaces, pile the cartons up in a single direction and in order.

\* Please place the product cartons away from the storage wall.

\* Please maintain the storage area with an appropriate ventilation. It is recommendable to furnish the storage area with equipments such as ventilation systems.

\* Please maintain the ambient temperature within the range of natural environmental fluctuation.

### Storage period

Within above mentioned conditions, maximum storage period should be one year.

DETAIL OF MODULE S/N LABEL

ENVIRONMENT READING THE NOTE

MODEL NAME

BARCODE

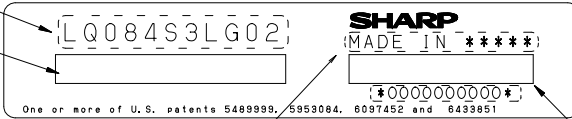

One or more of U.S. patents 548999, 5953004, 6097452 and 6439851

生産国/地域	
JAPAN	MADE IN JAPAN
CHINA	MADE IN CHINA

Barcode

Serial No. (5 digits)  
 Assembly site code  
 Discernment code  
 Production month (1-9X, Y, Z)  
 Production year (Last digit of dominical year)

\*COLD CATHODE FLUORESCENT LAMP IN LCD PANEL CONTAINS A SMALL AMOUNT OF MERCURY. PLEASE FOLLOW LOCAL ORDINANCES OR REGULATIONS FOR DISPOSAL.  
 \*当該液晶ディスプレイパネルは蛍光管が組み込まれていますので、地方自治体の条例、または、規則に従って廃棄してください。

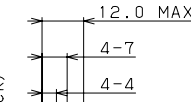
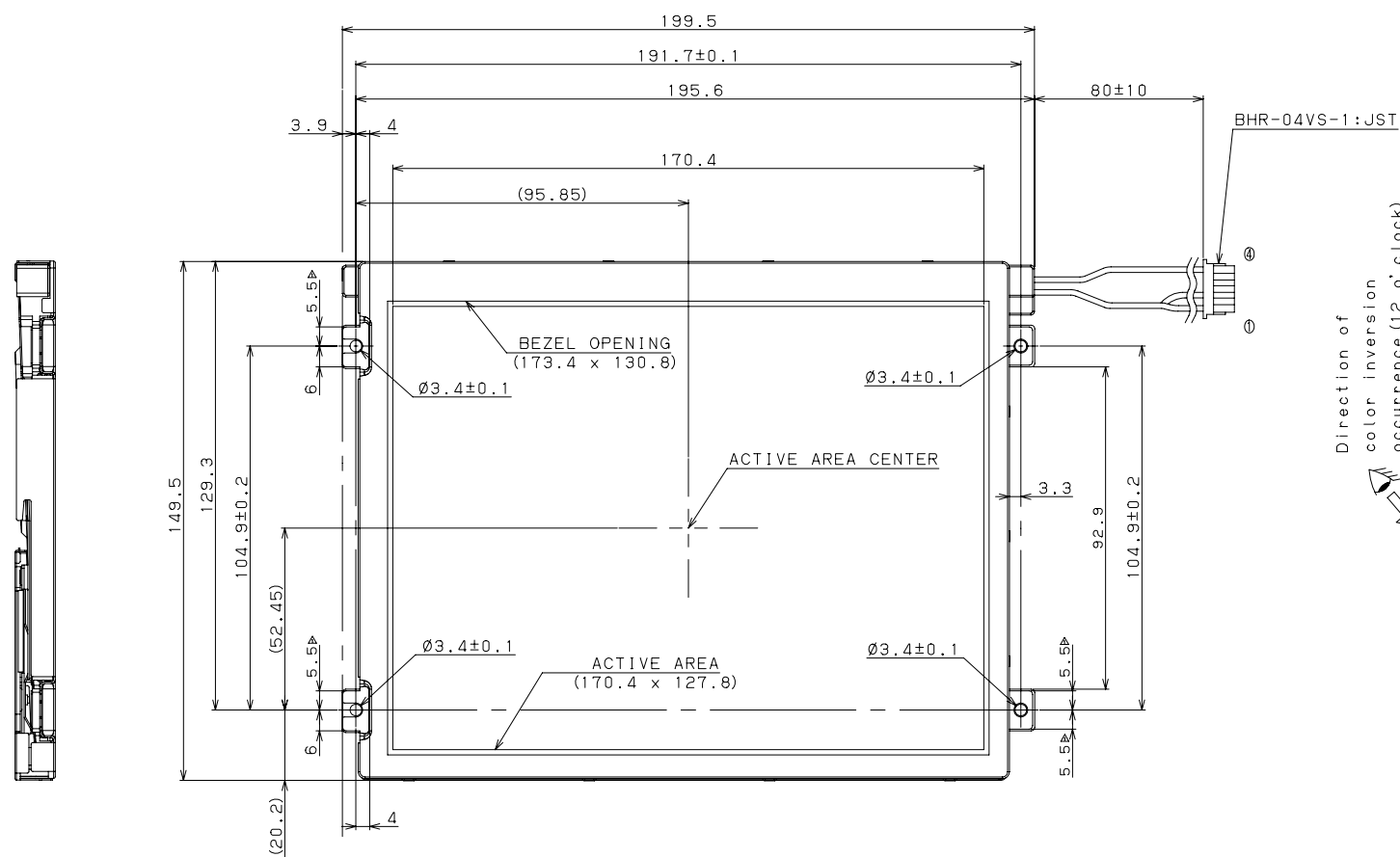

Direction of color inversion occurrence (12 o'clock)

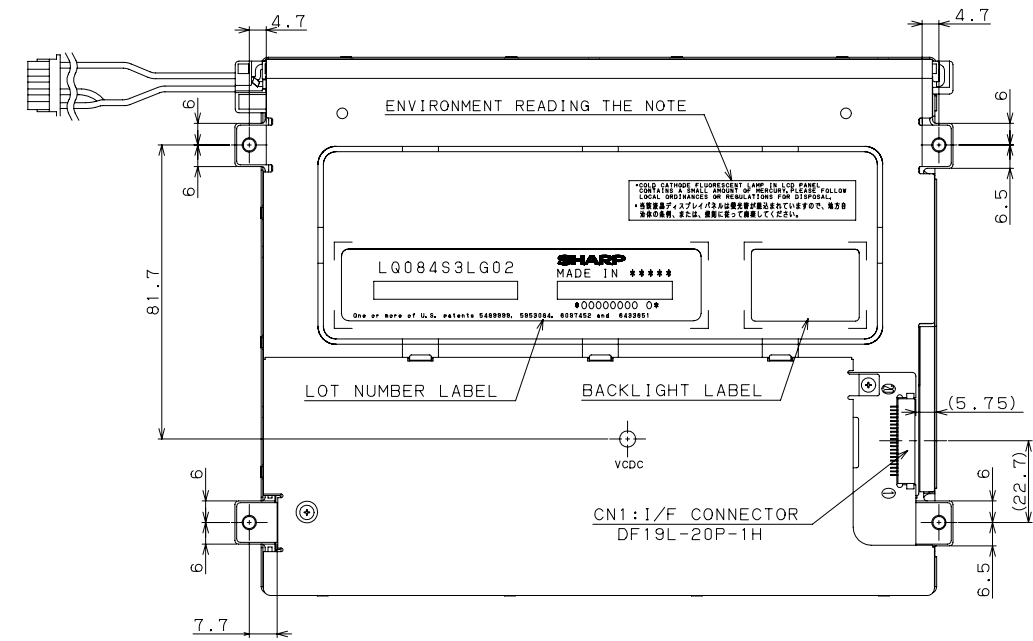

BEZEL/DISPLAY POSITION

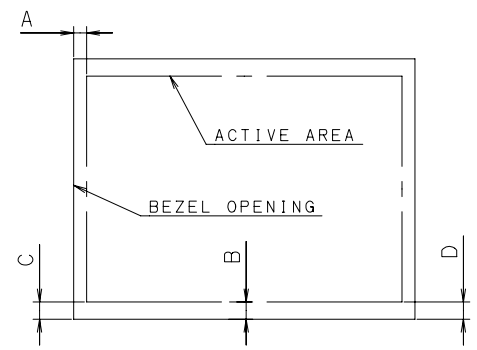

- 1) TOLERANCE X DIRECTION A: 1.5±0.8
- 2) TOLERANCE Y DIRECTION B: 1.5±0.8
- 3) OBLIQUITY OF DISPLAY AREA |C-D| < 0.8

NOTES)

- 1) UNSPECIFIED TOLERANCE TO BE ±0.5.
- 2) WARPING OF COMPONENTS SUCH AS TAPE, BEZEL, PCB, CHASSIS, FPC, PROTECTION COVER, ETC. ARE EXCLUDED FROM THICKNESS AND DIMENSIONS OF THE MODULE.
- 3) RECOMMENDED TIGHTEN TORQUE FOR MOUNTING  
 0.294±0.02N・m  
 (3.0±0.2kgf・cm)

CN1: DF19L-20P-1H (HIROSE)

pin	1	2	3	4	5	6	7
	VCC	VCC	GND	GND	RxIN0-	RxIN0+	GND
8	9	10	11	12	13	14	15
RxIN1-	RxIN1+	GND	RxIN2-	RxIN2+	GND	CK IN-	CK IN+
16	17	18	19	20			
GND	RxIN3-	RxIN3+	REV	8/6Bit			

CN2: BHR-04VS-1 (JST)

1	High
2	High
3	NC
4	GND

CORRESPONDING CONNECTOR: DF19G-20S-1C (HIROSE)

Fig1. LQ084S3LG02 OUTLINE DIMENSIONS

MASTER CARTON

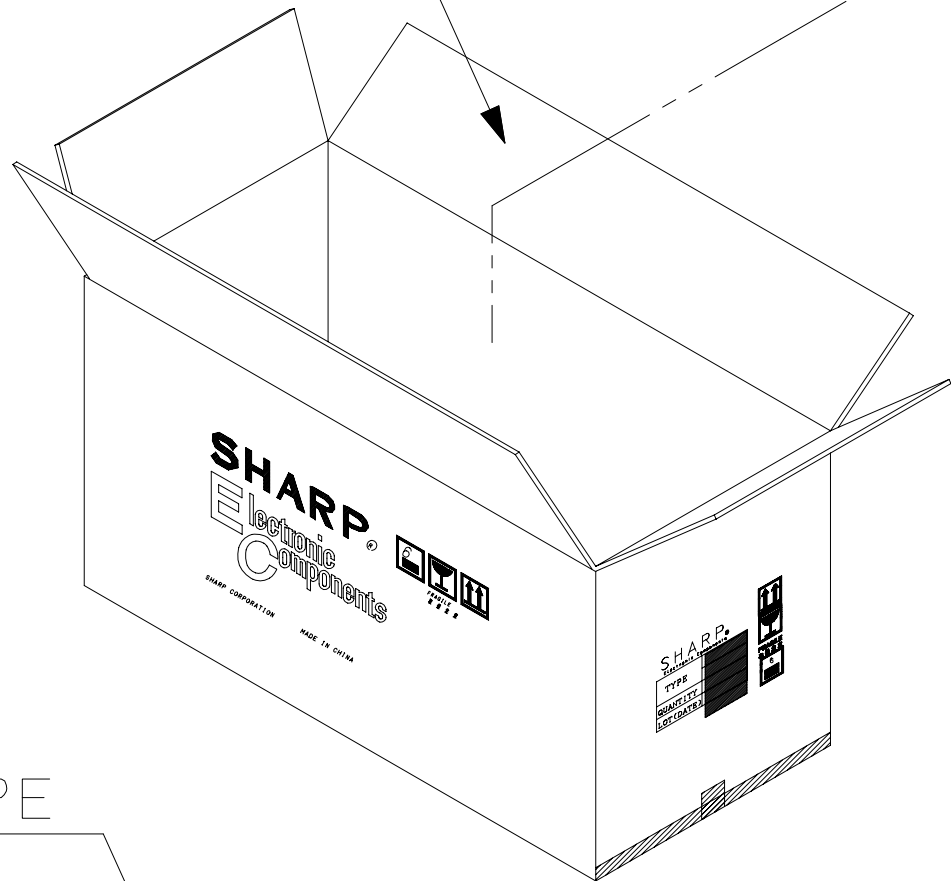

OPP TAPE

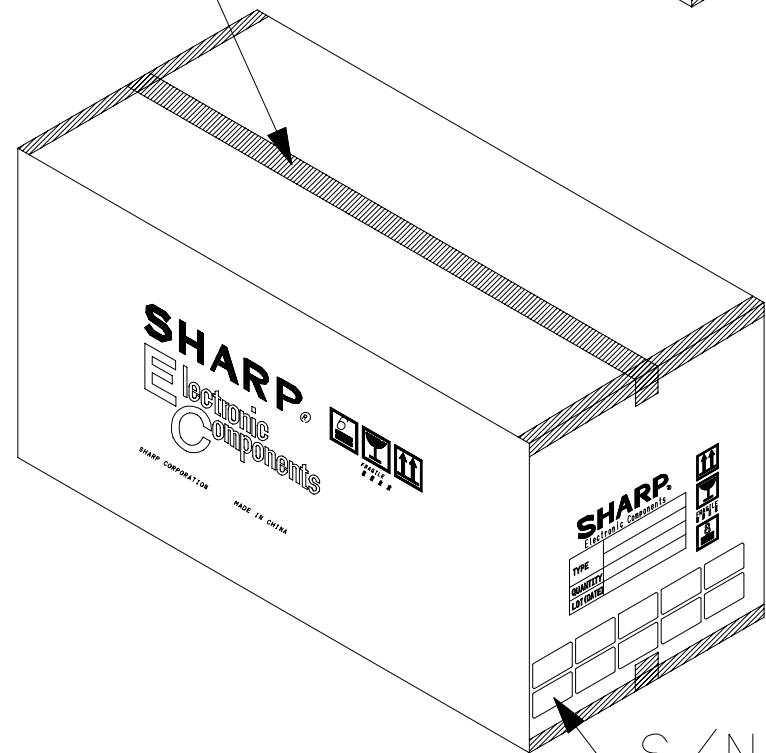

S/N LABEL

LD20754A-18

TOP TRAY

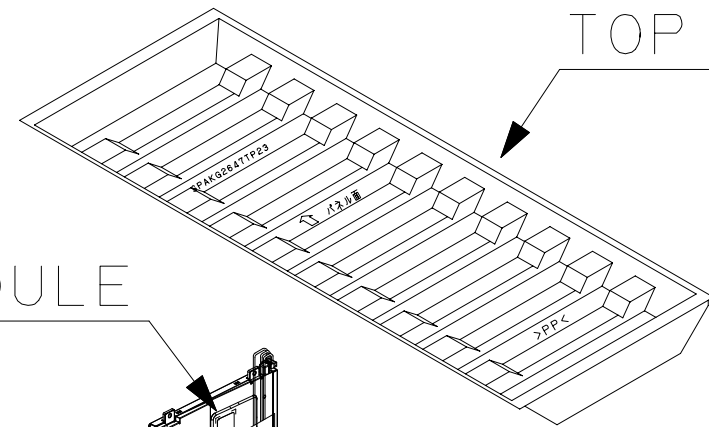

TFT-LCD MODULE

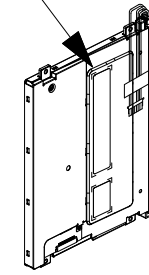

SIDE TRAY

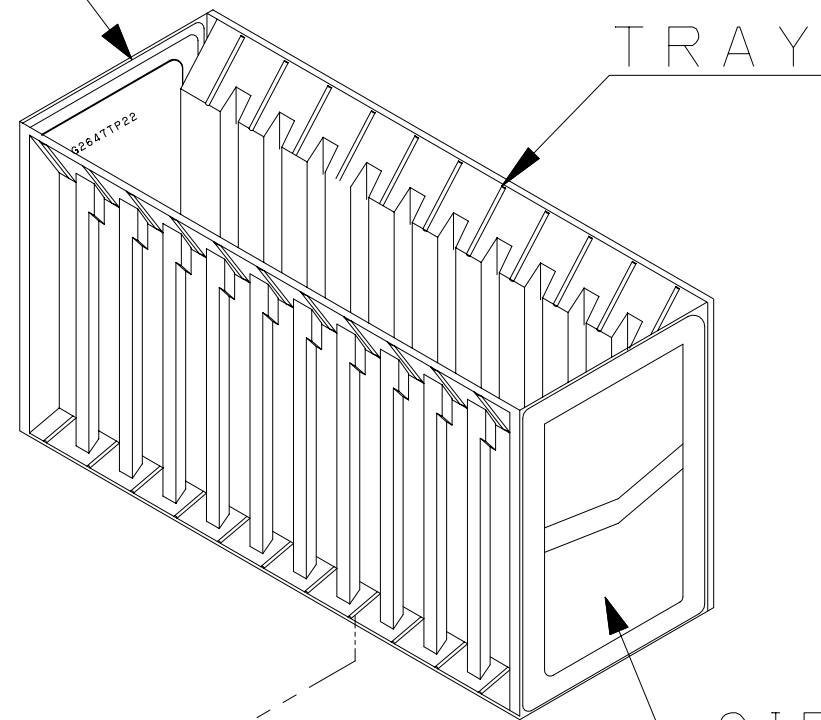

TRAY

SIDE TRAY

< Fig 3. PACKING FORM >