

XEA102 Frequently asked questions:

How do I install my XEA102?

Install the XEA102 using the fixing angle bracket provided with the register.

1. Thoroughly clean the location where the fixing angle bracket (B) is to be placed.
2. Peel off the adhesive tape on the fixing angle bracket.
3. Hook the angle bracket onto the hook (A) that is located at the bottom rear of the register.
4. Firmly stick the fixing angle bracket to the table surface that you cleaned in step 1.

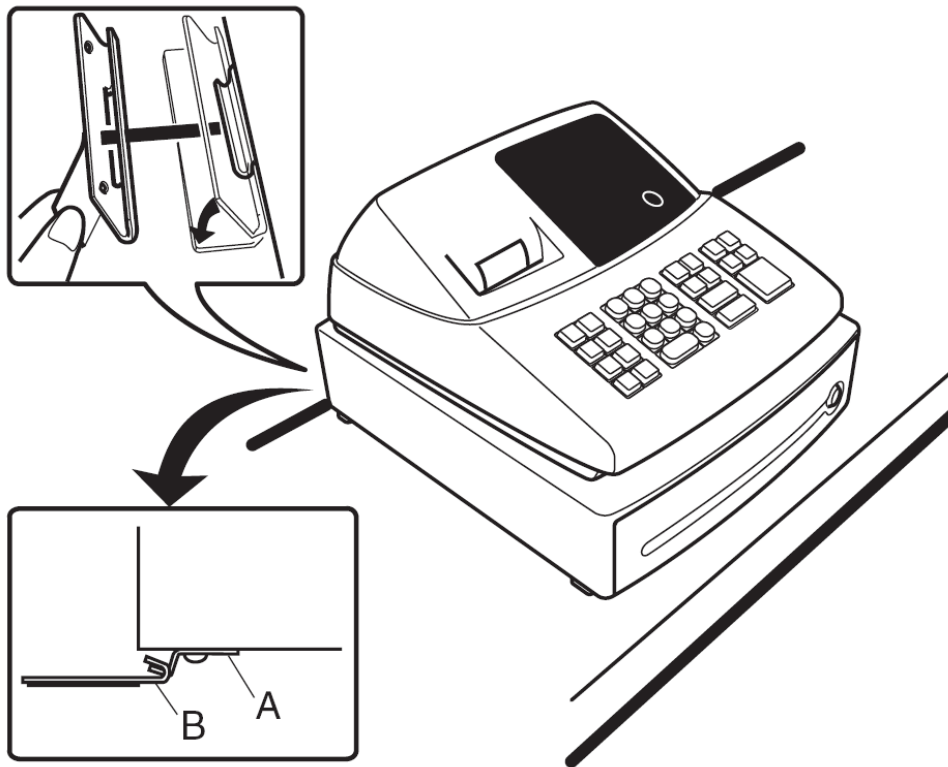

To remove the register from the fixing angle bracket:
Lift up the front of the register and pull the register towards you.

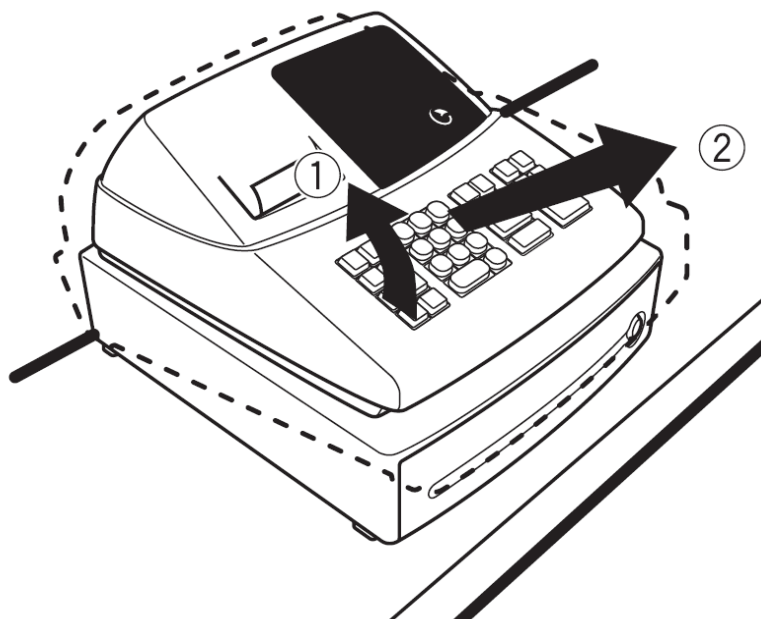

How do I Initialise the XEA102 so it is ready to be programmed?

To ensure that your cash register operates properly, initialize it using the following procedure.

1. Insert the mode key into the mode switch and turn the key to the REG position.

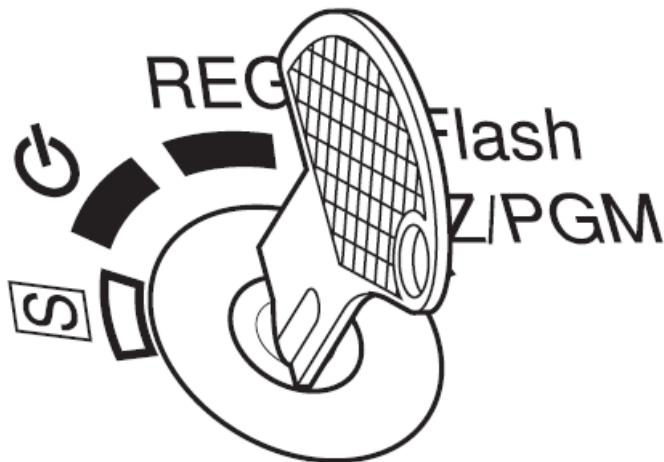



2. Insert the plug into the AC outlet. A buzzer will sound three times.

IMPORTANT:

This operation must be performed without batteries installed.

3. The register display should now show



4. Press the  key to confirm the clock starts from 0-00.
5. Press the  key to cancel the time display.

How and why do I install the Batteries?

Your XEA102 requires 3 x AA size batteries in order to maintain memory when: the mode key is in the “OFF” position, if there is a power failure, and/or the XEA102 is disconnected from the mains electricity supply. Once installed the batteries should last for approximately one year. Please see the answer to the question on how and when to replace the batteries for details on when to replace the batteries.

1. Pull the printer cover forward and detach it.

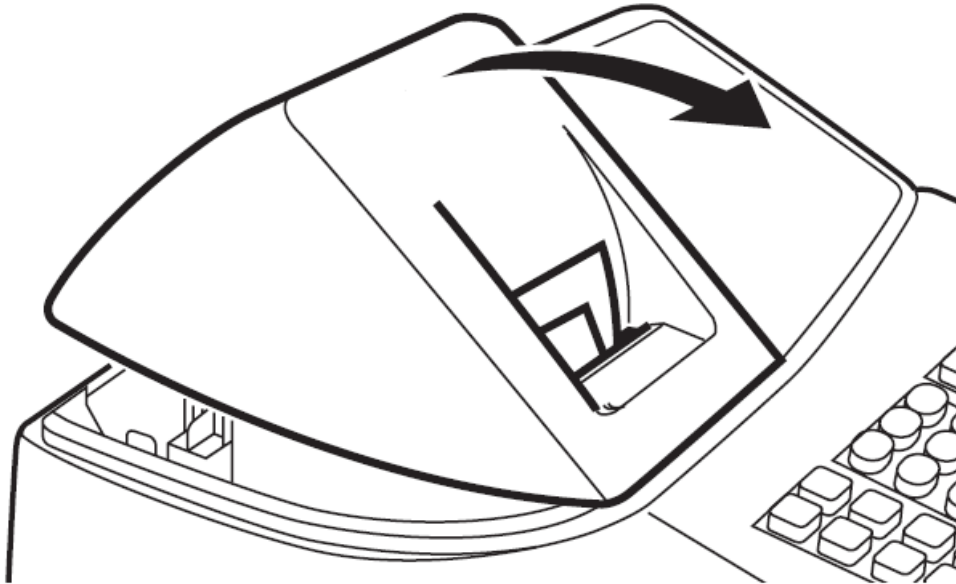

2. Open the battery cover next to the paper roll cradle.

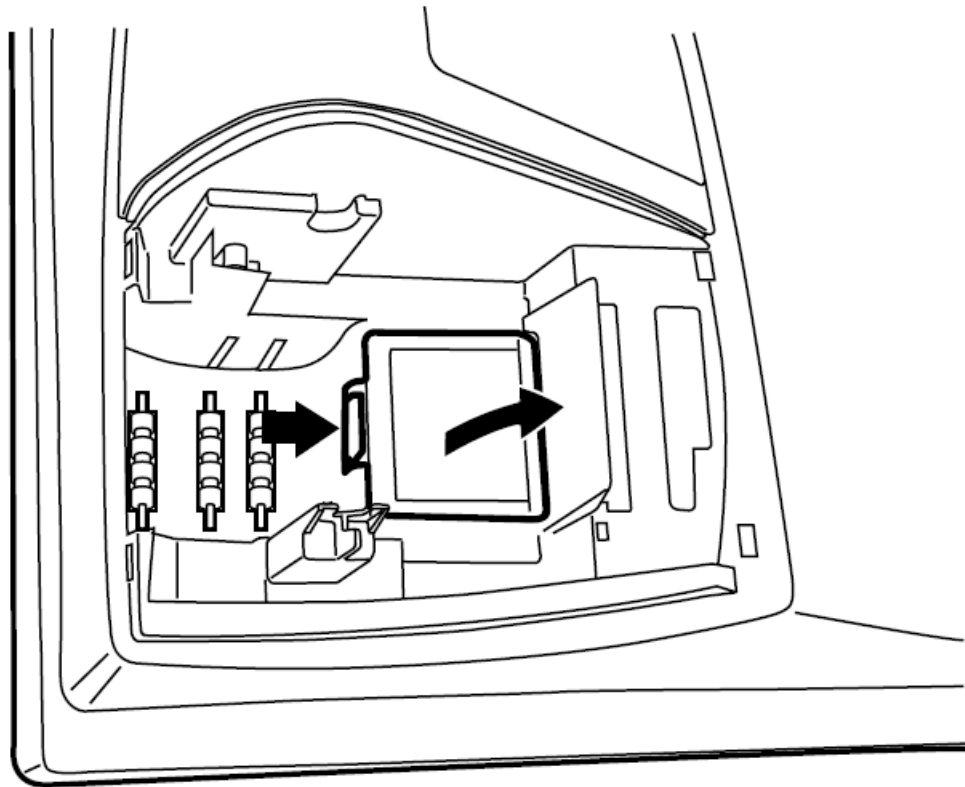

3. Install three new AA size batteries. Make sure that the batteries are installed as per the diagram below.

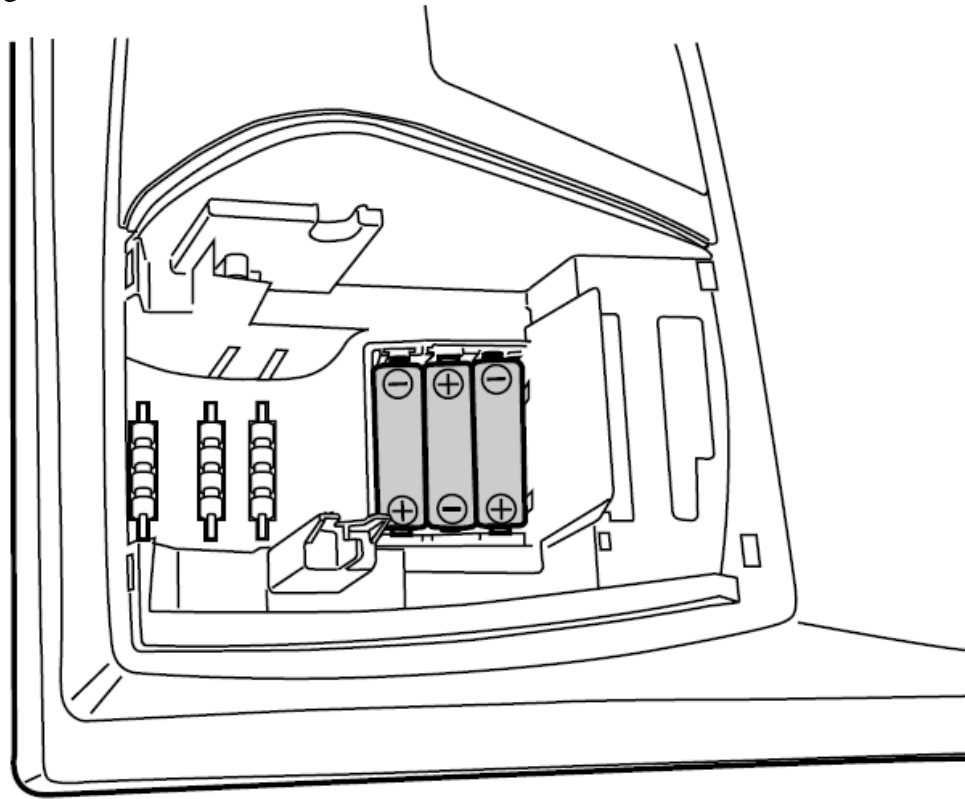



4. Confirm the “no battery” symbol  is no longer displayed.
5. Close the battery cover.

What sort of paper roll do I use, and how do I install it?

The XEA102 uses a bond paper roll which is: 57mm wide. Its maximum diameter should be no more than 80mm. The weight of the paper should be between: 47 to 64g/m².

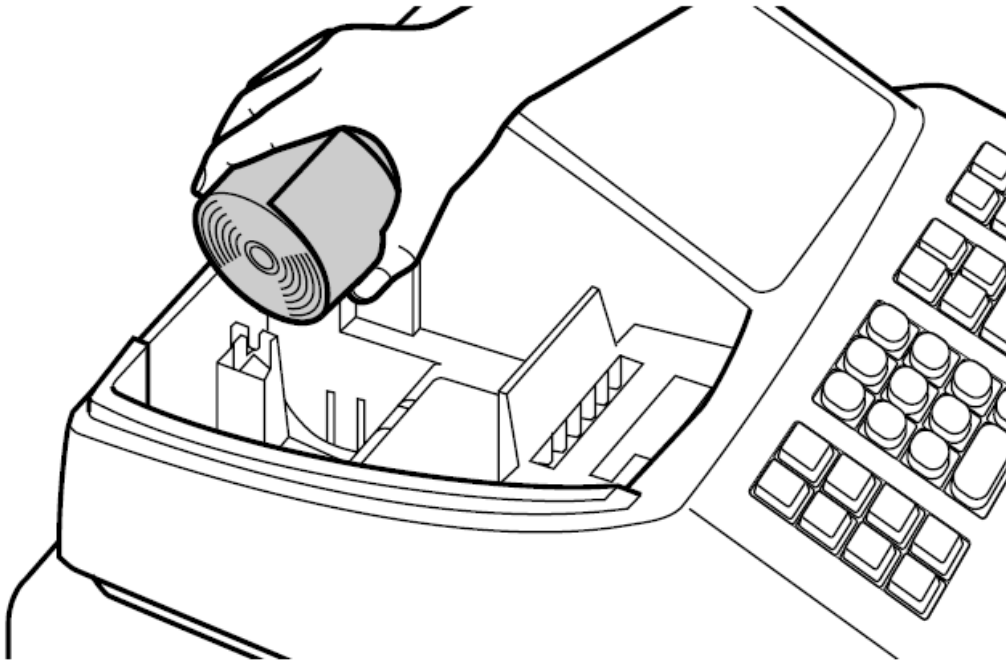
1. Set the paper roll in the paper roll cradle as shown in the diagram below.



2. Insert the paper straight into the paper inlet, and press the  key. The paper should then feed through and appear in the print area.

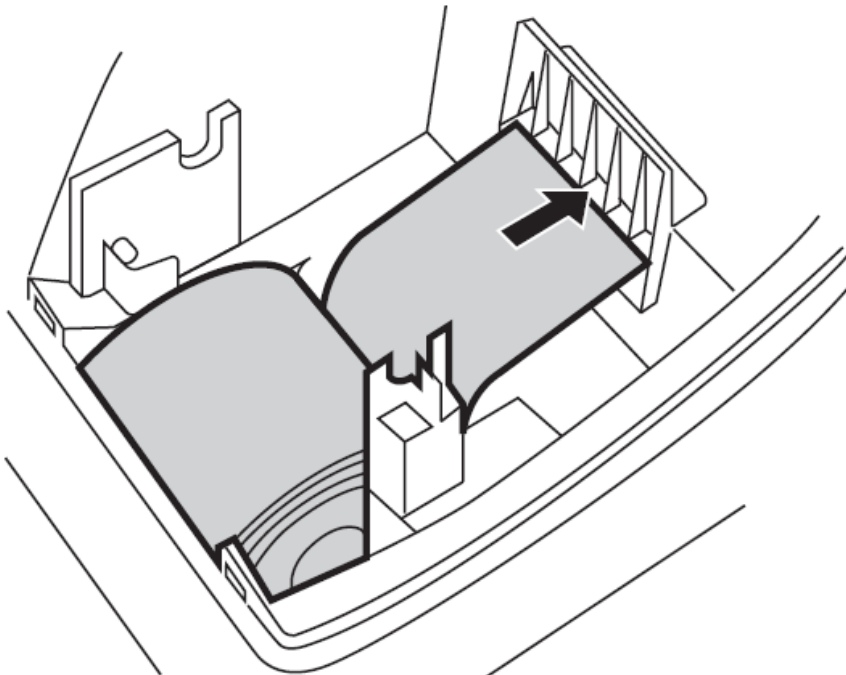

3. If you wish to use the paper take up spool please do the following
 - ❶ Insert the top end of the paper into the slit in the spool shaft and wind the paper two or three turns.
 - ❷ Put the spool shaft in the larger hole of the paper holding plate and push it in the direction of the arrow.
 - ❸ Place the take-up spool on the bearing.

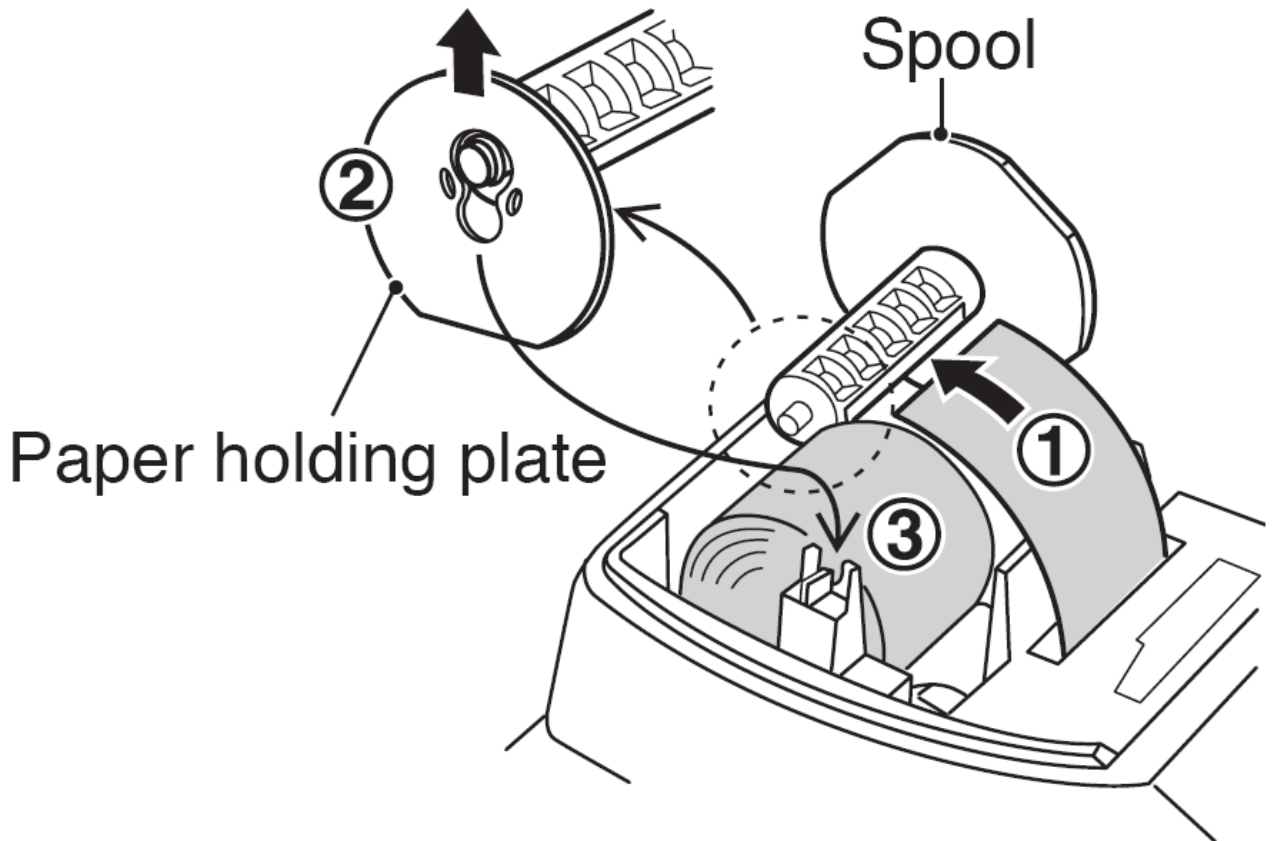

1. Replace the printer cover.

How do I set the Time and Date?

1. Set the mode key to the Z/PGM position

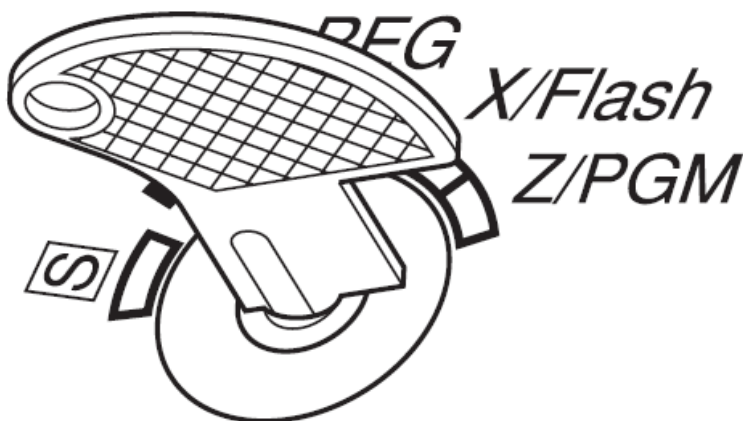

2. Enter the time in 4 digits (“hhmm” format) using the 24 hour system. For example 2:30pm would be entered as
3. Press the key once.
4. Enter the date in 6 digits using the day-month-year format. For example 18th of October 2009 would be entered as
5. Press the key once. A program report will print.

How do I set a 10% GST rate?

1. Set the mode key to the Z/PGM position

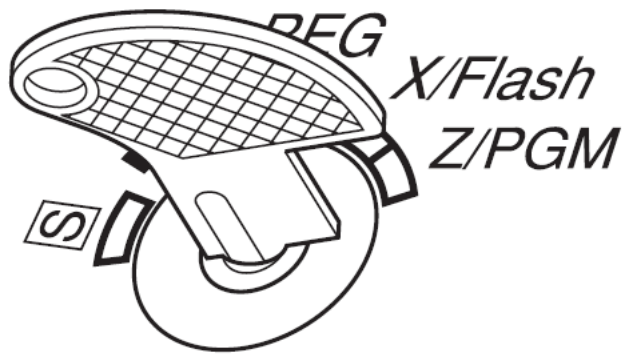

2. To set the Tax system to “Auto VAT 1 – 4” (this is the system used for GST). Enter the following:

3. To set the tax rate to 10%. Enter the following:

4. Press twice. A programming report will print.

How do I set a Department as Taxable or Not Taxable?

1. Set the mode key to the Z/PGM position

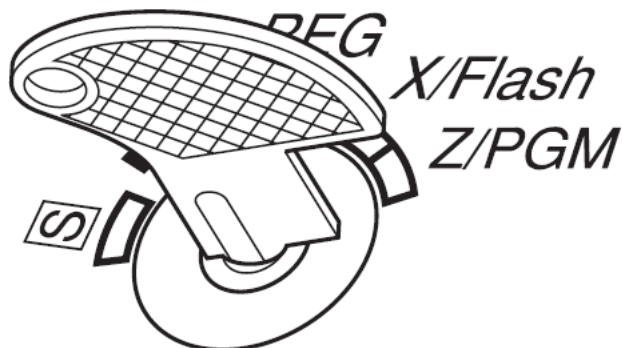

2. To set a department as “not taxable”, enter the following:

3. Repeat if required for other departments, press before the department key when setting departments 5 to 8.

4. To Set a department as “taxable”, enter the following:

5. Repeat if required for other departments, press before the department key when setting departments 5 to 8.

6. Press again. A programming report will print.

How do I set the printer to print: a receipt, journal, or nothing?

The XEA102's printer can be set to print: a receipt, or journal, or nothing in REG mode. Reports will always print in the Z/PGM mode regardless of the setting for REG mode. Note: The journal spool will not turn if the XEA102 is set to: receipt, or no print.

1. Set the mode key to the Z/PGM position

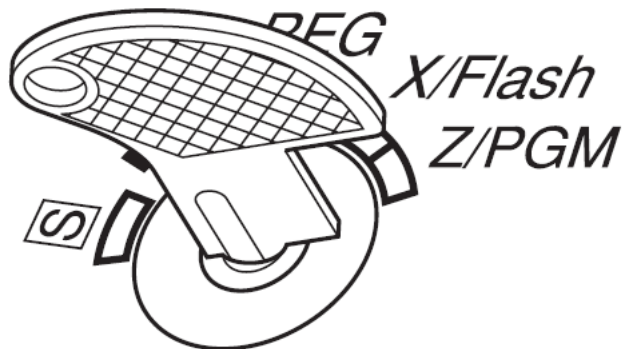

2. To set the printer for receipt printing, do the following:

3. Press again. A programming report will print

4. To set the printer for journal printing, do the following:

5. Press again. A programming report will print

6. To set the printer for no printing, do the following:

7. Press again. A programming report will print.

I have set a programming secret code. How do I clear it?

The XEA102 can have a secret code set so only authorised operators may use the Z/PGM mode.

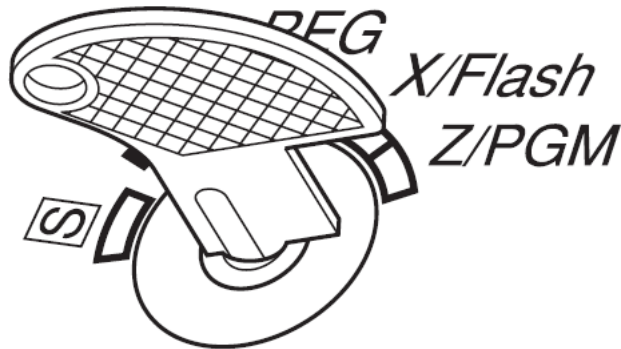

1. Set the mode key to the Z/PGM position



2. If you wish to clear a Z/PGM secret code do the following:

0 0 0 0 ⊗/TM TL/AT/NS

How do I know when it is time to change the batteries?

The XEA102 has a “Low Battery” symbol which is:  , and a “Flat Battery/No Battery” symbol which is: 

When the “Low Battery” symbol is displayed you should replace the batteries with new ones within two days of it being first displayed. Failure to do so will mean that the XEA102 might lose its programmed settings and any sales data in the event of a power failure.

When the “Flat Battery/No Battery” symbol is displayed the battery must be replaced immediately. If not the XEA102 will lose all its programmed settings, and any sales data if the power fails or is turned off.

How do I replace the Ink Roller for the Printer?

When the printing becomes faded, replace the existing ink roller with a new one. Please contact a supplier of the Sharp XEA102 for assistance in obtaining a new ink roller.

Precautions:

Never “re-ink” a used roller.

Only remove a new roller from its packaging for immediate use.

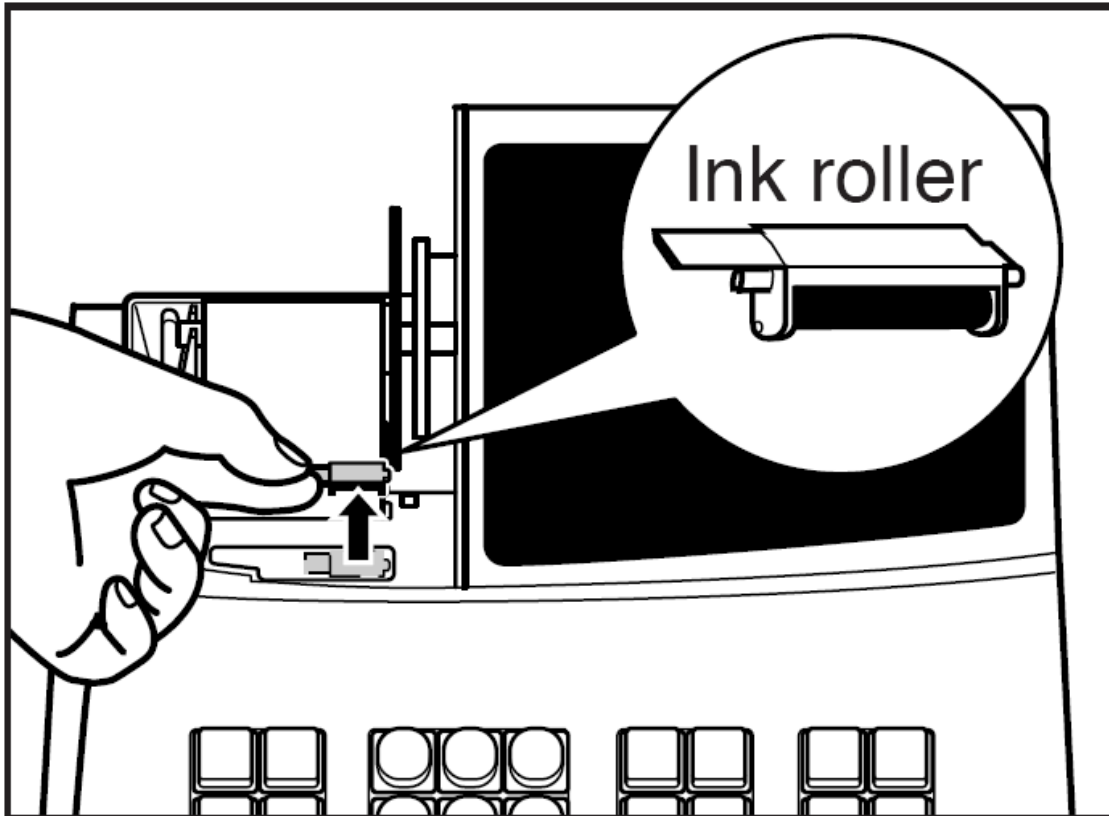

1. Remove the printer cover.
2. Pull the ink roller handle upward to remove the ink roller.
3. Install the new ink roller
4. Replace the printer cover.

How do I produce Sales Reports?

There are 3 types of sales reports:

Flash reports for viewing on the display

Use this function for on-the-spot checking of individual cash registers totals such as: Cash in Drawer. The information is displayed but not printed. The information is not cleared from the cash register's memory.

To display the following register totals turn the mode key to the X/Flash position, and press the keys indicated below:

Individual Department sales total:

Sales Total:

Cash in Drawer:

X (eXamine), reports for printing a reading of the sales

This report prints the accumulated sales information. Taking an X report is a good way to make a mid-day check on daily sales. You can take X reports any number of times, because they do not affect the cash register's memory.

To issue an X report turn the mode key to the X/Flash position and press the key indicated below:

X report printout:

Z (Zero), reports for printing a reading of the sales, then clearing the sales totals

This report prints the same information as an X report. Once this report has been printed, the cash register's memory of daily information is cleared, and all the transaction totals are reset to zero. There are two types of Z report. One which does not clear the grand totals, and one which does.

To issue a Z report: turn the mode key to the Z/PGM position and press the keys indicated below:

Z report printout without clearing of the grand total:

Z report printout with clearing of the grand total:

Please refer to page 16 of the user manual for details on the reports contents.