

Reverse Cycle Airconditioning from Sharp



Regardless of the temperature outside, you can create a comfortable, pleasant environment inside your home with a Sharp reverse cycle split system air conditioner. Warm in winter and cool in summer, reverse cycle air conditioning puts you in control through every season.

How does reverse cycle air conditioning work?

To put it simply, a split system air conditioner has an indoor unit that is fitted to a wall inside your home, and a compressor unit that sits outside your home. The indoor and compressor units work together to cool and warm the air.

The cooling cycle

Reverse cycle air conditioners have the ability to transfer heat from one place to another.

In cooling mode, the indoor unit draws warm air from the room and extracts the heat from it. The heat energy is transferred through copper pipes by the refrigerant to the compressor unit outside where it is released.

The air inside the indoor unit is now much cooler and is recirculated into the room.

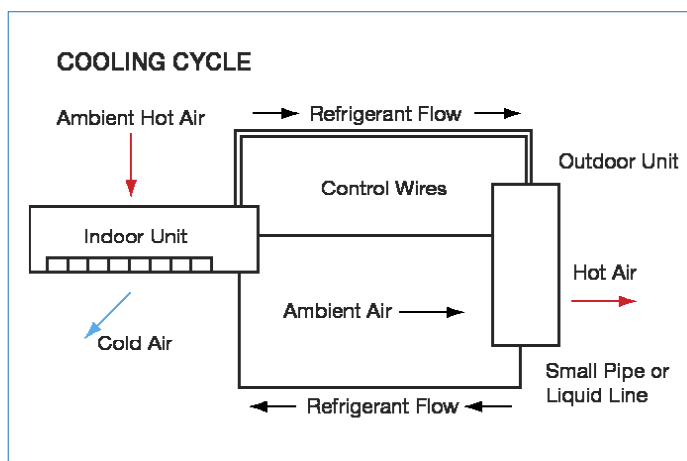

The heating cycle

To heat your home the reverse occurs. The compressor unit is made extremely cold, similar to a freezer, which creates a large difference in temperature between the compressor unit and the outside air.

Heat is drawn from the air outside, transferred through copper pipes and released through the indoor unit to increase the room temperature.

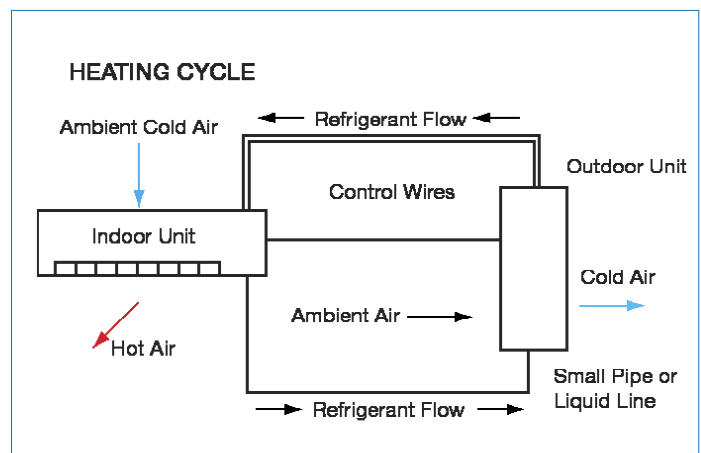

What is Inverter Technology?

An inverter air conditioner has the ability to vary its output power or capacity to suit the environment.

Inverter air conditioners work by using a high power operation to cool or heat a room to the set temperature. After reaching the set temperature, the operation is maintained at a low constant power.

Inverter air conditioners simply reduce the output capacity to maintain the desired room temperature keeping the compressor operating continuously.

Another benefit of the inverter technology is less noise. All that you hear is a continuous low whirring sound as the motor gradually changes speed, rather than turning on and off like conventional air conditioners.

SHARP



Specifications

Model No – Complete Unit	AC09RLCSYS		AC12RLCSYS		AC18RLCSYS		AC24RLCSYS	
Function	Cooling	Heating	Cooling	Heating	Cooling	Heating	Cooling	Heating
Output Capacity (KW)	2.6	2.85	3.5	3.85	5.3	5.6	6.50	7.20
Energy Efficiency Star Rating	6	6	5.5	4.5	4.5	4	4	4.5
Total Capacity (W) (High/Standard)	2600/1188	2850/1109	3500/1233	3850/830	5300/1610	5600/1217	6500/2250	7200/1800
Total Capacity (Btu/H) (High/Standard)	9000/4063	9800/3792	12000/4200	13000/2830	18000/5500	19100/4150	22200/7700	24550/6150
Power Input (W) (High/Standard/Low)	1200/610/264	1250/670/230	1400/1000/262	1450/1066/233	2100/1540/370	2300/1610/398	2600/2000/550	3100/1990/500
Rated Input (W)	610	670	1000	1066	1540	1610	2000	1990
Rated Current (A) (High/Standard)	5.5	6.0	6	6.3	10.7	11.5	11.3/8.7	13.5/8.7
Rated Voltage	220~240V		220~240V		220~240V		220~240V	
Frequency (Hz)	50Hz		50Hz		50Hz		50Hz	
Moisture Removal (L/h)	0.8		1.2		3.0		4	
Indoor Unit	AYX09LCJ		AYX12LCJ		AYX18LCJ		AYX24LCJ	
Sound Pressure Level dB (A)	38		38		45		45	
Dimensions (WxDxH) (mm)	872 x 178 x 283		872 x 178 x 283		955 x 197 x 285		1090 x 208 x 330	
Net Weight / Gross Weight (kg)	12/15		12/15		12/15		17.5/22.5	
Model of Outdoor Unit	AEX09LCJ		AEX12LCJ		AEX18LCJ		AEX24LCJ	
Compressor Type	Twin Rotary		Twin Rotary		Twin Rotary		Twin Rotary	
Working Temp Range (°C)	-7°C ≤ T ≤ 43°C		-7°C ≤ T ≤ 43°C		-7°C ≤ T ≤ 43°C		-15°C ≤ T ≤ 46°C	
Defrosting Method	Auto defrost		Auto defrost		Auto defrost		Auto defrost	
Sound Pressure Level dB (A)	54		54		56		58	
Sound Power Level dB (A)	64		64		66		68	
Dimensions (WxDxH) (mm)	848 x 320 x 540		848 x 320 x 540		846 x 300 x 685		950 x 340 x 840	
Net Weight / Gross Weight (kg)	40/45		40/45		52/57		64/69	

*Rating Conditions (Cooling) – Inside air temperature: 27°C D.B. 19°C W.B. Outside air temperature: 35°C D.B. 24°C W.B

Design and specifications are current as of October 2009 but are subject to change without notice. Colour variations to products may occur due to printing.



To find out which Sharp system is right for your room, visit <http://www.sharp.net.au> and select the Room Size Calculator.

SHARP

Sharp Corporation of Australia Pty Limited ABN 40 003 039 405
 1 Huntingwood Drive, Huntingwood NSW 2148
 Ph: (02) 9830 4600 Fax: (02) 9672 1207 www.sharp.net.au